

PERRIN

Super Shifter Stop for 2015+ WRX w/OEM STI Short Throw Shifter

2022-12-27

PSP-INR-022

Thank you for purchasing this PERRIN product for your car! Installation of this product should only be performed by persons experienced with installation of aftermarket performance parts and proper operation of high performance vehicles. If vehicle needs to be raised off the ground for installation, the installer must use proper jacks, jack-stands and/or a professional vehicle hoist for safety of the installer and to protect property. If the vehicle is lifted improperly, serious injury or death may occur! Please read through all instructions before performing any portion of installation. If you have any questions, please contact our tech department prior to starting installation. We can be reached in any of the following methods:

Email Tech@PERRIN.com

Instant Chat off the main page of www.PERRIN.com

Or simply call our tech team at 503-693-1702



WARNING: This product can expose you to chemicals including Lead which is known to the State of California to cause cancer birth defects or other reproductive harm. For more information, go to www.P65Warnings.ca.gov

GENERAL MODIFICATION NOTE

Modifications to any vehicle can change the handling and performance. As with any vehicle extreme care must be used to prevent loss of control or roll-over during sharp turns or abrupt maneuvers. Always wear seat belts, and drive safely, recognizing that reduced speeds and specialized driving techniques may be required. Failure to drive a vehicle safely may result in serious injury or death. Do not drive a vehicle unless you are familiar with its unique handling characteristics and are confident of your ability to maintain control under all driving conditions. Some modifications (and combinations of modifications) are not recommended and may not be permitted in your state or country. Consult the owner's manual, service manual, instructions accompanying these products, and local laws before purchasing and installing these modifications. You are responsible for the legality and safety of the vehicle you modify using these components.

Special Notes:

- This will not work on cars with ANY short throw shifter installed. See PERRIN.com for more information.
- A 7mm open ended wrench is needed to install this part. This is mentioned as this is not commonly found in most basic tool kits.
- Spending time making the stop as little as possible while still being able to select each gear can result in a very nice tight feeling shifter. Below are our recommendations for a quick trouble-free install that leaves about 1/8" of play at the shift knob.

Parts Included with the PERRIN Shifter Stop:

QTY	Part Number	Description
(1)	X-BLT-M5KHS	M5 Short Arm Hex Key
(2)	X-BLT-M6X25CS-SS	M6 X 25 Head Socket Cap Screw SS
(2)	X-BLT-M6X16CSL-SS	M6 X 16 Socket Cap Screw SS
(2)	X-BLT-M6WF-SS	M6 Flat washer Stainless Steel
(1)	X-PSP-INR-018BK	Shifter Stop for 2015+ WRX
(1)	X-PSP-INR-022FRD	Shifter Stop Front for 2015+ WRX w/OEM STI Short Shifter Red
(1)	X-PSP-INR-022RRD	Shifter Stop Rear for 2015+ WRX w/OEM STI Short Shifter Red

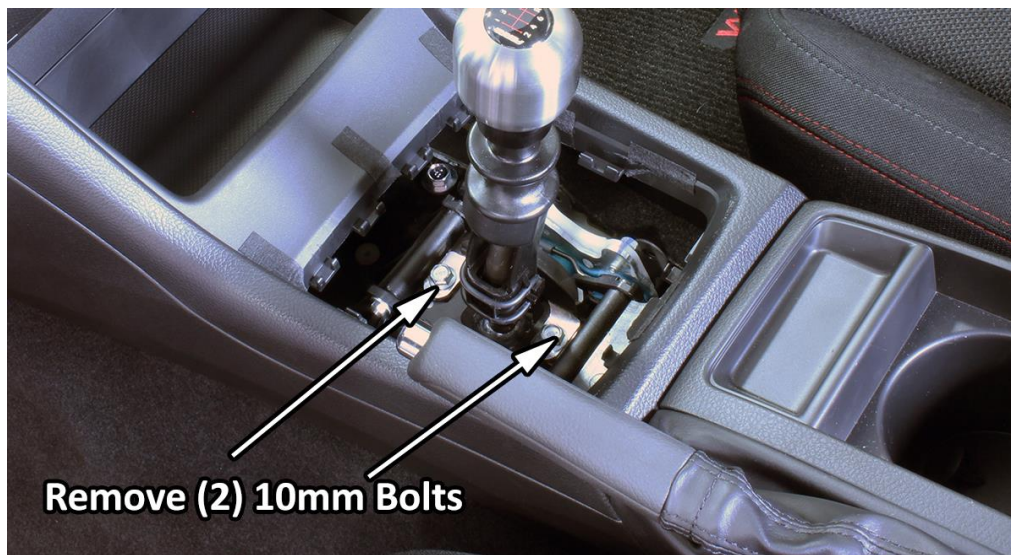

Installation Instructions:

1. Remove shift knob from car and place shifter into neutral.
2. Grab around inside edges of shifter boot and silver trim ring. Pull straight up to remove shift boot and ring in one step. This will expose shifter mechanism.
3. Place car into 5th gear and take note of gap between OEM plastic stop and shifter rod. This gap is adjustable but also very important to ensure that reverse can't be selected during a 5th to 6th shift.
4. Locate and remove (2) 10mm bolts (shown in picture above) securing black plastic 5th & 6th gear shifter stop. **Note: Once bolts are removed, shifter stop will slide left to right. At this time it is not important as to its location.**

Start with shifter stop pushed all the way to the left side

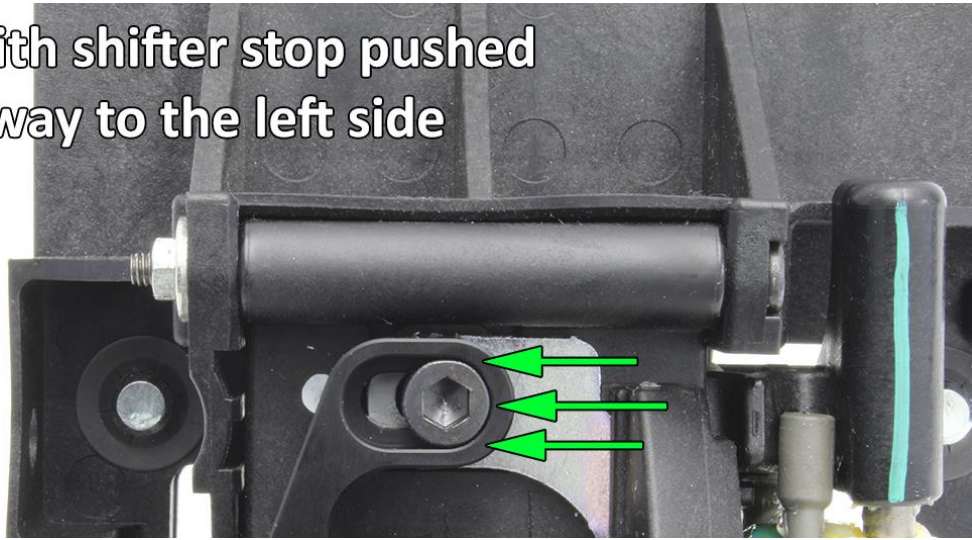

5. Install PERRIN Shifter Stop (black "C" shaped part) using supplied M6x16 bolts. Leave bolts finger tight at this time.
6. During the next few steps, there will be two adjustments being made at one time, 1&2 Gate Stop and 5&6 Gate Stop. Be patient while adjusting and tightening down.
7. With 5th gear still selected, slide OEM plastic stop over to shifter until it barely touches. Wiggle the shifter back and forth roughly 1/8 of an inch at the knob. This creates a small gap between the shifter and the shifter stop.
8. Carefully pull the shifter out of 5th gear and place it into 1st gear.
9. Slide PERRIN Shifter Stop up to shifter until it just barely touches. Wiggle shifter back and forth roughly 1/8 of an inch at the knob. This creates a small gap between the shifter and the shifter stop. Tighten M6 bolts to just beyond hand tight, to secure both shifter stops in place.

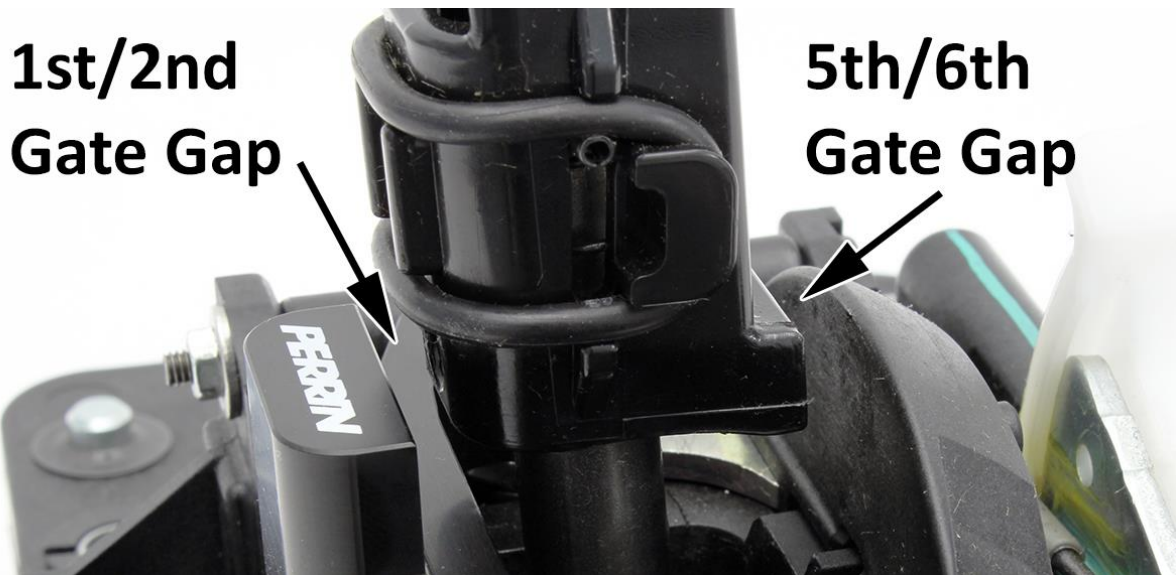

Above picture shows shifter in neutral. Actual gaps when 1st/2nd gear or 5th/6th gear are selected, will be much smaller.

10. Make sure that all gears are easily selectable with clutch pedal depressed. Test that there is a small amount of wiggle when shifter is placed in 1st or 2nd gear, and also 5th or 6th gear.
 - a. **Note #1: The small amount of wiggle room can be adjusted so there is even less, but great care must be taken to ensure that all gears are easily selectable. If this is not adjusted properly transmission damage can occur!**
 - b. **Note #2: It is critical that reverse is NOT selectable during normal 5th to 6th shifts. Reverse should ONLY be reachable by using the reverse lock out lever. If this is not adjusted properly transmission damage can occur!**
11. Using a 7mm wrench, remove (2) small nuts on left side of shifter mechanism. **Note: Be careful not to drop nuts! Using a magnetic pickup might be a good idea just in case you start to lose it.**

**Make Sure Washers
Are Centered Under
Nuts**



12. Install supplied M6 SS washers over studs sticking out, then reinstall nuts removed in step above. Leave loose at this time.
13. Slowly tighten nuts with fingers until washers just start to touch plastic body. As best as possible, center each washer under each nut, and tighten nuts about $\frac{1}{2}$ a turn. Tighten nuts down slightly more than hand tight or until gap in outer and inner plastic housing is taken up. **Note: Tightening nuts, then loosening, then retightening may help centering washers. Also, be very careful when tightening nuts as these are very small and can strip or break.**

**Tighten Nuts
To Remove This
Gap**



14. Locate small tabs on shifter and trim off as shown in picture below. This can be done with an X-acto knife or Dremel type tool. Make sure to clean up the debris left behind after they are removed.

**Remove Lower
Parts of Tabs
As Shown**

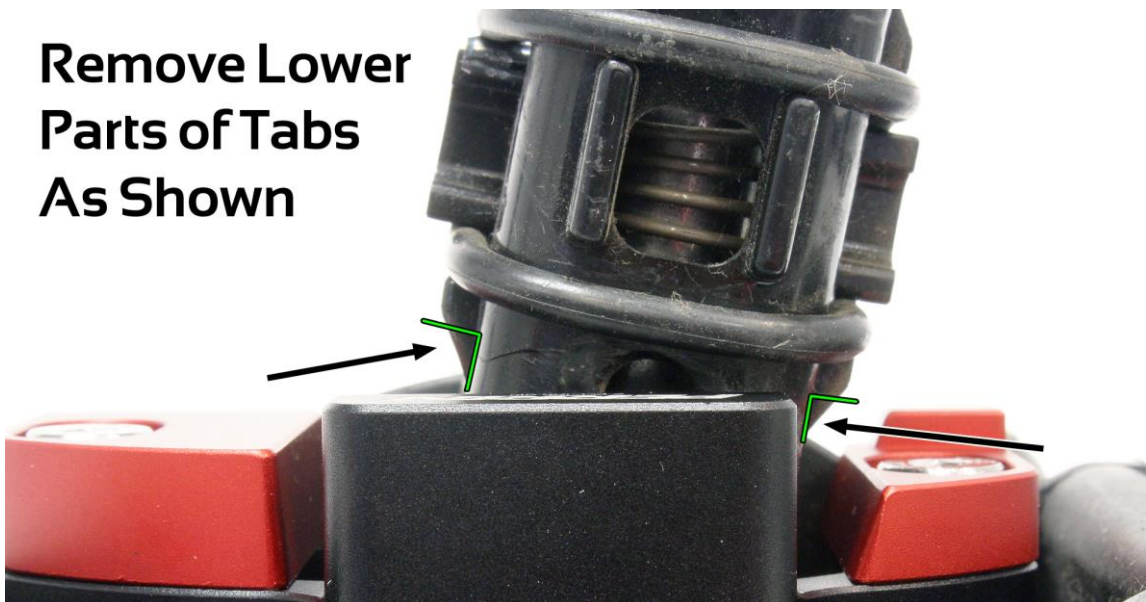

15. Remove front M6 bolt securing PERRIN Shifter Stop (Black "C" shaped part) and install supplied PERRIN Front Shifter Stop (Red part with "022F" engraved on bottom) into slot as shown picture below.
16. Install supplied M6x25 bolt to secure in place and tighten to 10ft-lbs.
17. Remove rear M6 bolt securing PERRIN Shifter Stop (Black "C" shaped part) and install supplied PERRIN Rear Shifter Stop (Red part with "022R" engraved on bottom) into slot as shown picture below.
18. Install supplied M6x25 bolt to secure in place and tighten to 10ft-lbs.

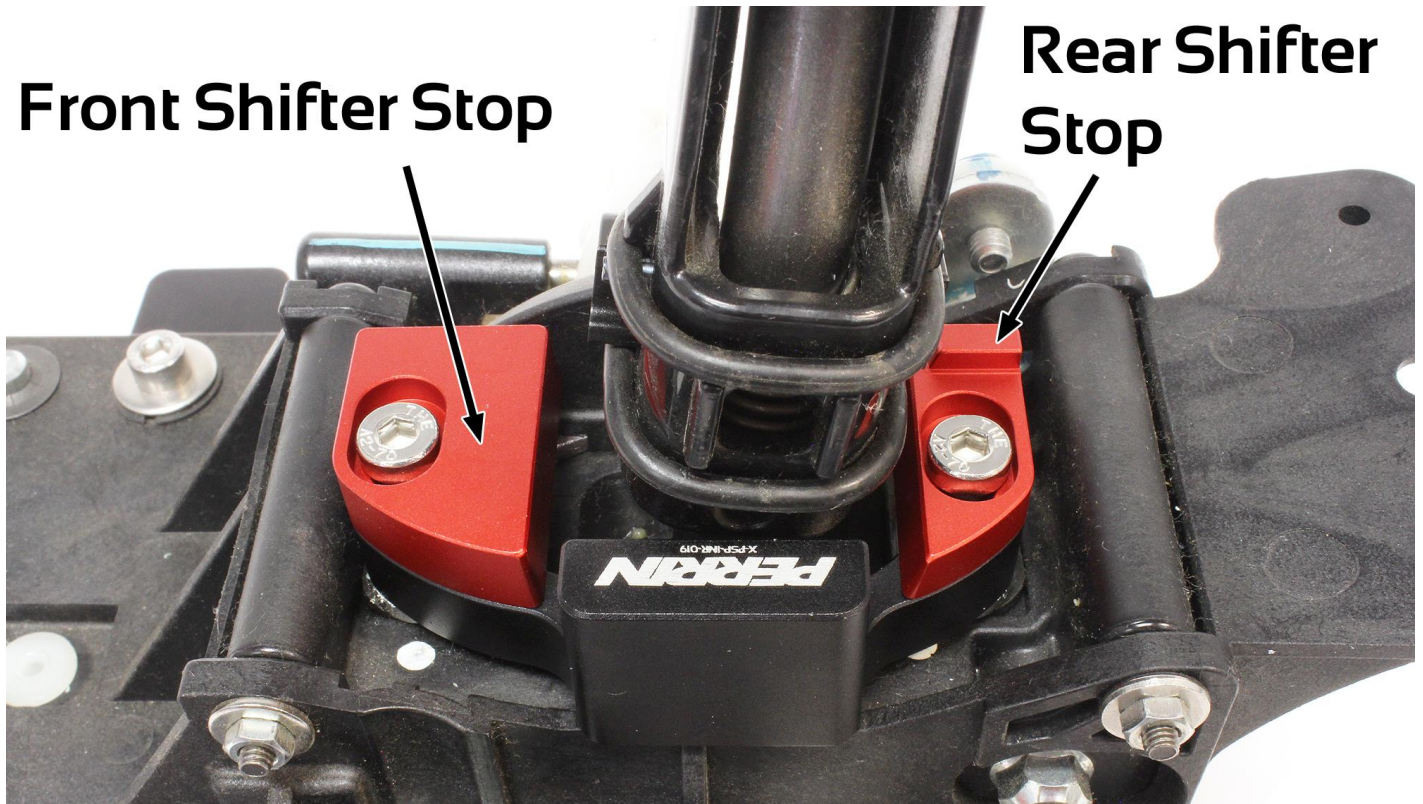

Checking For Play In Shift Knob

The amount of play found in the shift knob is very important to have to ensure proper engagement of each gear position. If there is NO play in the shift knob after the installation and adjustment has occurred, STOP and remove the parts as transmission damage may occur! If you have an excessive amount of play in the shift knob, it may indicate some aftermarket parts are installed that you are unaware of, or the wrong part number was installed.

1. Depress clutch and shift into 3rd gear, then release the clutch.
2. The shifter should hit the PERRIN Shifter Stop (red part) when you push it forward and when you pull it toward neutral it should stop on the internal stops built inside of the transmission.
 - a. This "play" in the shift knob should be around 1/4"
 - b. This play indicates that you are able to fully select the gear without interference from the PERRIN Shifter Stop.
 - c. If there is NO play or it takes excessive force to hit the PERRIN Shifter Stop as described, see adjustment section below before removing.
3. Depress clutch and shift into 4th gear, then release the clutch.
4. Just as in the above step, the shifter should hit the PERRIN Shifter Stop (red part) when you pull it toward the back of the car and when you push it toward neutral it should stop on the internal stops built inside of the transmission.
 - a. This "play" in the shift knob should be around 1/4"
 - b. This play indicates that you are able to fully select the gear without interference from the PERRIN Shifter Stop.
 - c. If there is NO play or it takes excessive force to hit the PERRIN Shifter Stop as described, see adjustment section below before removing.
5. Shift transmission into all gears and check that a similar amount of play is felt though the entire range. If there are some differences in how it feels see adjustment section below.
6. Install shifter boot back onto center console and reinstall shift knob.
7. Recheck shifter mechanism allows all gears to be easily selected and take for a test drive.
8. Re-check hardware after a week of driving. **Note: it will be normal to find some wear on the plastic part of the shifter.**

Make Sure Shifter Has Roughly 1/4" Of Play When In Gear

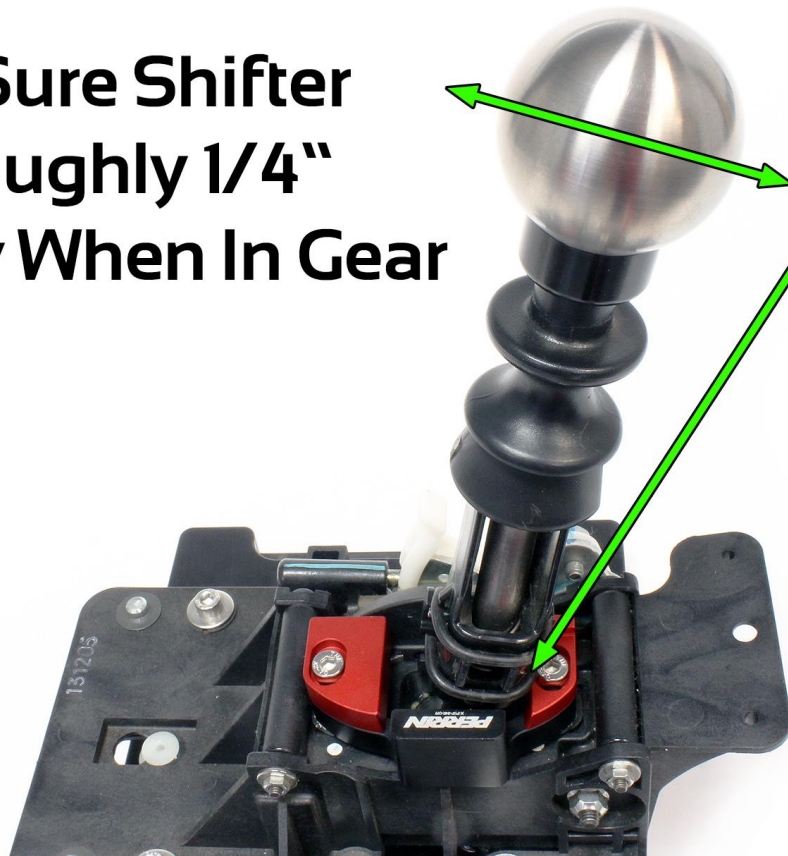

Play Is In The Shifter Hitting The PERRIN Shifter Stop And Moving Toward Neutral

Adjustment of PERRIN Shifter Stops

As mentioned above, NO play in the shift knob can cause damage to the transmission. If you are unable to adjust the PERRIN Shifter Stop so there is the 1/4" or so of play at the knob, then remove parts and do NOT drive the car. If there is excessive play in the knob and you can't adjust it using the below steps, damage to the transmission will NOT occur but this may indicate you have some aftermarket parts you are unaware of or the wrong part number is installed.

Some adjustment may be needed, or some aftermarket part may be installed that you are unaware of.

- If the play is different from the front 1/3/5 gears to back 2/4/6 gears, loosen the (2) M6 bolts and move the entire PERRIN Shifter Stop Assembly front to back slightly to adjust the play to be the same. Make sure to check the left to right shifter stops after any adjustment to ensure nothing has changed and that reverse is NOT selectable during a 5th to 6th gear change.
- There is a slight rotational adjustment of the PERRIN Front and Rear Shifter Stops. Adjusting these can also aid in making all the play in all the gears match.
- If after adjusting all (3) parts, if NO play is found in shift knob, remove parts from car and determine if incorrect part number was purchased or aftermarket parts were installed that you were unaware of. Contact PERRIN Tech Support to help with further trouble shooting.

Questions, Comments and Suggestions Contact: Tech@PERRIN.com

Visit Our Website for Instant Chat Options at www.PERRIN.com

Call Our Tech Team at 503-693-1702