

WARNING: DO NOT EXPOSE WORK AREA TO ANY SPARKS OR FIRE. DO NOT SMOKE WHILE OPERATING ON THE FUEL SYSTEM. CLEAN UP ALL FUEL SPILLS IMMEDIATELY. WORK IN A WELL VENTILATED AREA.

1. Disconnect the battery negative terminal, as shown. Allow the engine to cool before working with the fuel system. Have a rag handy and purge fuel pressure from the system using the Schrader valve on the front of the OEM fuel rail.

Disconnect the 8 fuel injectors. Note that the wiring harness is specific to the firing order. If the wiring harnesses are removed, they must be reinstalled on the correct engine bank and to each specific injector.

Disconnect any wiring, vacuum lines, and throttle body components interfering with the installation process.



2. Using an SAE disconnect tool, remove the fuel feed hose. Catch all spilled fuel. Use a 10mm socket to remove the four M6 mounting bolts (511). These bolts will be reused.

Gently lift the fuel rails up being careful to not lose anything in the engine bay. The injectors will remain attached to the fuel rails. Remove from the vehicle and place onto a bench. Pull out and save all 8 injector retaining clips (510) as they will be reused. Cautiously pull and twist to remove the injectors. Note: the rail will contain residual fuel. Drain excess fuel into a safe container for disposal.

Clean out any dirt or debris found in the intake manifold injector seat bores.

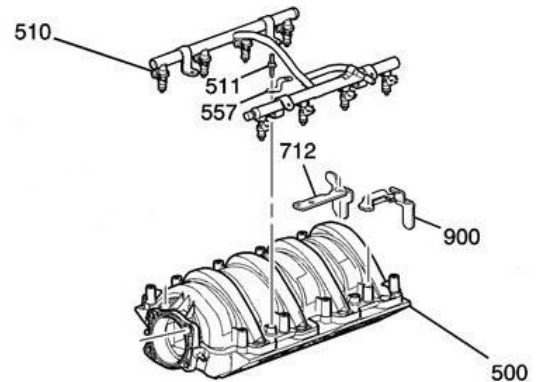

3. Apply a medium strength thread locker to the eight provided M6 bolts. Using a 4mm Allen hex wrench, install the mounting feet as shown.

Make sure the mounting feet are perpendicular to the rails.



4. Prepare to install the necessary adapter fittings into each fuel rail port. The 20-0361 fuel rail does not include plumbing (adapters, fittings, hoses, etc). **To avoid damage, lubricate all O-rings with oil prior to installing.**



5. Before installing the fuel injectors, be sure the inlet cone filters are free from debris. Also, inspect the injector O-rings for any damage and replace if necessary.

For ease of installation, apply a light coat of oil to the injector O-rings, intake manifold injector seats, and fuel rail injector bores.

Fully insert the injectors into the fuel rail bores. Reinstall the OEM injector clips, as shown.

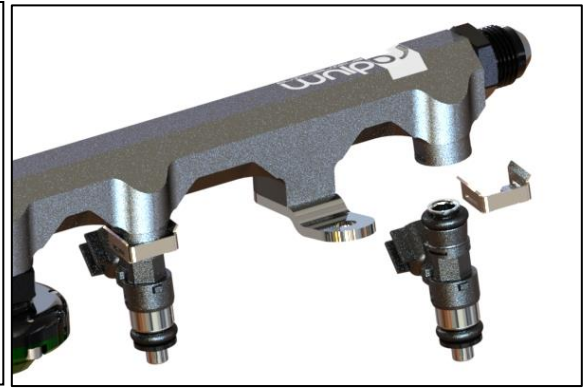

6. Line-up and place each fuel rail assembly onto the intake manifold. Once everything is positioned correctly, push the rail towards the intake manifold to fully seat the injectors. Confirm all injector O-rings have been installed properly.

Note: There are OEM brackets at the rear of the rails (shown in green). Depending on which port fittings are used, there may be interference. Modifications to these brackets may be required.

Tighten the 4 OEM mounting bolts.

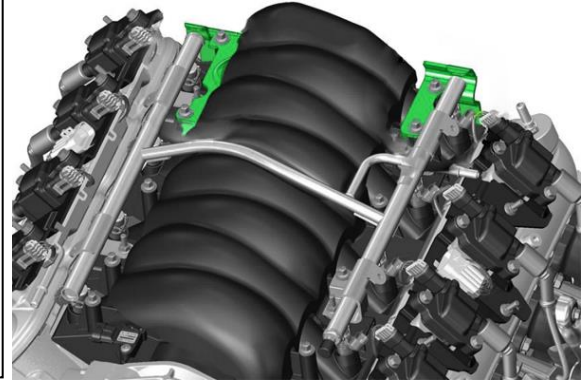

7. Reinstall all components previously removed.

Cycle the ignition switch a few times (without starting engine). This purges the system of air and allows the fuel pump to prime the system.

CHECK FOR LEAKS! If no leaks are found, start the engine and check again while the engine is running. NOTE: OEM fuel pressure is 4 bar (GM states "55-60psi").

Installation complete.

