

Installation for Chevrolet Corvette C7 Stingray & ZO6
(Standard exhaust) PN's - 11862, 11863, 11868, 11869, 11877, 11878, 11880, 11881
(Optional NPP) PN's - 11874, 11855, 11875, 11856
ZO6 PN's - 11902, 11903, 11904, 11905, 11908, 11909, 11910, 11911



These instructions have been written to help you with the installation of your Borla Performance Exhaust System. Please read this document completely before beginning the installation of your system.

Please compare the parts in the box with the bill of materials provided to assure that you have all the parts necessary for this installation.

To ensure this part number fits your specific model year, please visit our website for the latest model year listings at www.BORLA.com.

Thank you for purchasing a Borla Performance Rear Section Exhaust System.

Borla Performance Rear Sections (PN's - 11862, 11863, 11868, 11869, 11877, 11878, 11880, 11881, 11910, 11911) are designed for the C7 Corvette Stingray (6.2L V8 engine) and ZO6 (6.2L Supercharged engine), automatic or manual transmissions, Coupe or Convertible.

Borla Performance Rear Sections (PN's - 11874, 11855, 11875, 11856, 11902, 11903, 11904, 11905) are designed for the C7 Corvette Stingray (6.2L V8 engine, w/ optional NPP) and ZO6 (6.2L Supercharged engine), automatic or manual transmissions, Coupe or Convertible.

Borla Performance Industries recommends that an exhaust shop or professional after market parts installer, who has all the necessary equipment, tools and experienced personnel needed for proper installation, should perform the installation of this system. However, if you decide to perform the installation, we recommend someone should help you. Ensure the installer uses all under car safety precautions including eye protection.

Please take time to read and understand the following...

By installing your Borla Performance Exhaust System, you indicate that you have read this document and you agree with the terms stated below.

It is the responsibility of the purchaser to follow all installation instruction guidelines and safety procedures supplied with your Borla Performance Exhaust System.

Borla Performance Industries assumes no responsibility for damages occurring from misuse, abuse, improper installation, improper operation, lack of responsible care, or all previously stated reasons resulting from incompatibility with other manufacturer's products and/or systems.

Included with your Borla Performance Exhaust System is a warranty card. Please read it carefully before you begin any work on your vehicle. If you should have any questions regarding our warranty policy, installation, or any other matter pertaining to your new Borla Performance Exhaust System, please give us a call at the number provided on the warranty card.

Minimum Required Tool List:

TOOLS:

1. 3/8" Drive Ratchet
2. 3/8" Drive Extension 9"
3. 18mm Socket
4. 3/8" Universal Swivel
5. 15mm Socket
6. 13mm Socket
7. 10mm Socket
8. 8mm Socket
9. 7mm Socket
10. Pry Bar

SHOP SUPPLIES:

- 1 Spray Lubricant

Borla Performance - Bill of Materials

11862

| ITEM NO. | QTY. | PART NUMBER | DESCRIPTION |
|----------|------|-------------|-------------------------------|
| 1 | 1 | 55283 | RH OVER AXLE TUBE W/AFM VALVE |
| 2 | 1 | 55282 | LH OVER AXLE TUBE W/AFM VALVE |
| 3 | 1 | 55289 | R/H MUFFLER ASSEMBLY |
| 4 | 1 | 55290 | L/H MUFFLER ASSEMBLY |
| 5 | 2 | 90116 | 3/5 ACCUSEAL CLAMP Ø2.75 |
| 6 | 2 | 22051 | CLIP-ON NUT: M8 X 1.25mm |
| 7 | 4 | 92010 | WASHER: FLAT, M10 |

11863

| ITEM NO. | QTY. | PART NUMBER | DESCRIPTION |
|----------|------|-------------|-------------------------------|
| 1 | 1 | 55283 | RH OVER AXLE TUBE W/AFM VALVE |
| 2 | 1 | 55282 | LH OVER AXLE TUBE W/AFM VALVE |
| 3 | 1 | 55291 | R/H MUFFLER ASSEMBLY |
| 4 | 1 | 55292 | L/H MUFFLER ASSEMBLY |
| 5 | 2 | 90116 | 3/5 ACCUSEAL CLAMP Ø2.75 |
| 6 | 2 | 22051 | CLIP-ON NUT: M8 X 1.25mm |
| 7 | 4 | 92010 | WASHER: FLAT, M10 |

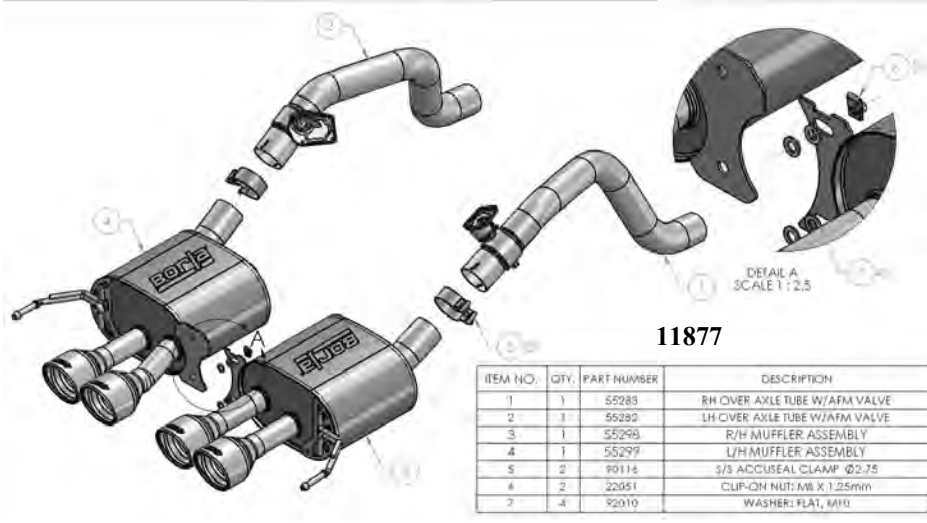
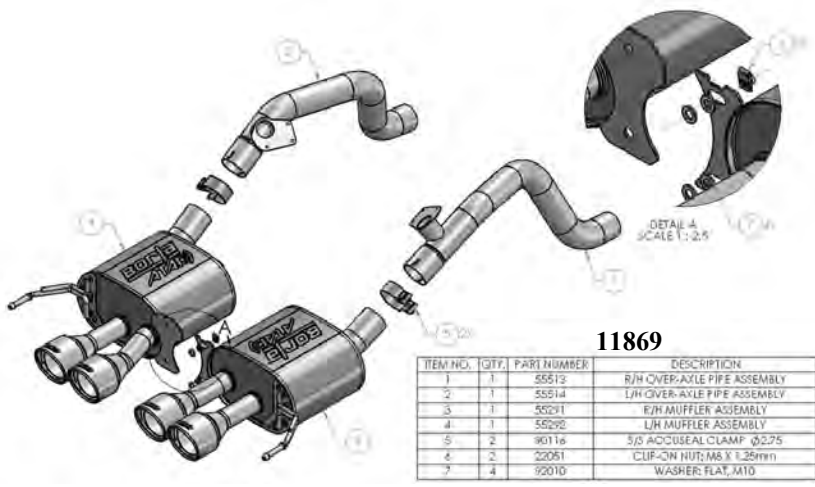
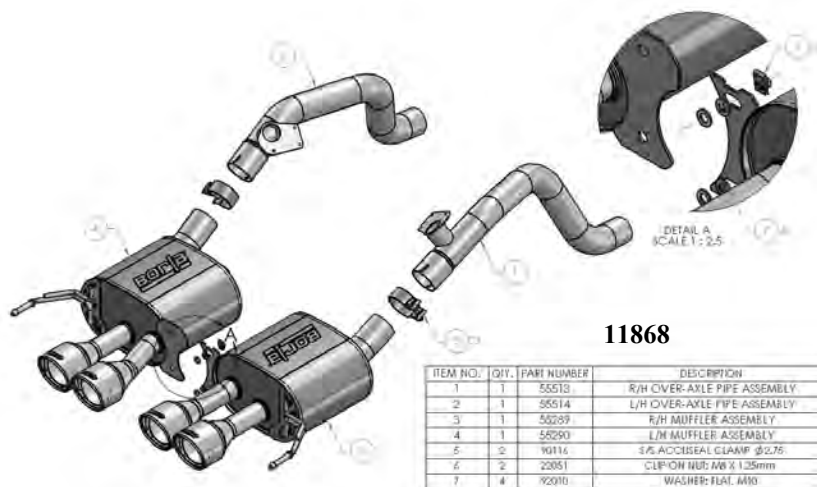

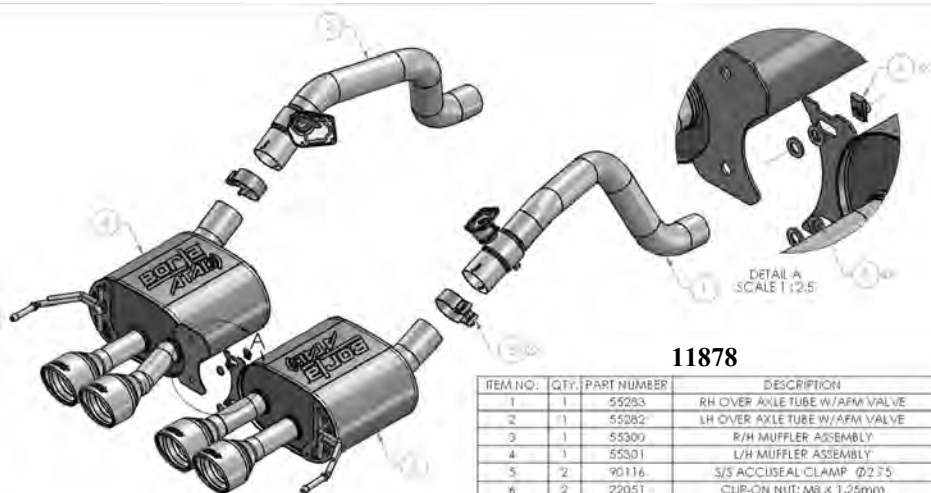

11878

| ITEM NO. | QTY. | PART NUMBER | DESCRIPTION |
|----------|------|-------------|--------------------------------|
| 1 | 1 | 55283 | R/H OVER AXLE TUBE W/AFM VALVE |
| 2 | 1 | 55282 | L/H OVER AXLE TUBE W/AFM VALVE |
| 3 | 1 | 55300 | R/H MUFFLER ASSEMBLY |
| 4 | 1 | 55301 | L/H MUFFLER ASSEMBLY |
| 5 | 2 | 90116 | S/S ACCUSEAL CLAMP Ø2.75 |
| 6 | 2 | 22051 | CLIP-ON NUT: M8 X 1.25mm |
| 7 | 4 | 92010 | WASHER: FLAT, M10 |

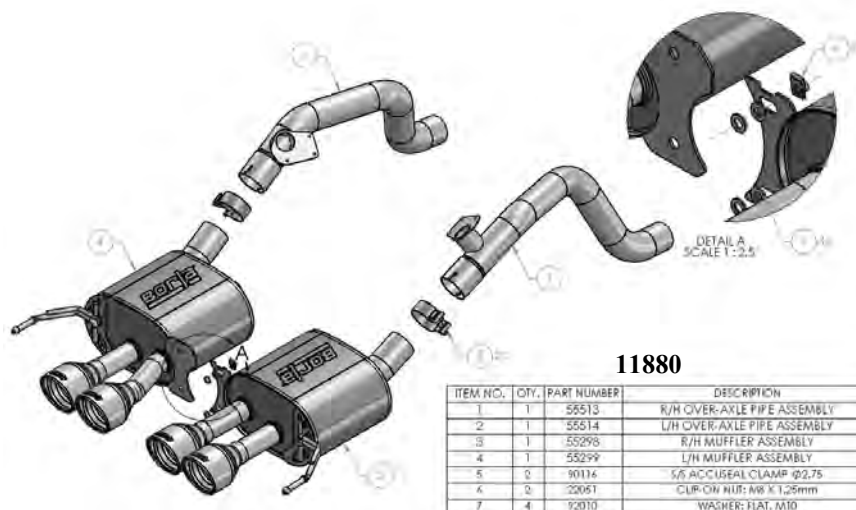

11880

| ITEM NO. | QTY. | PART NUMBER | DESCRIPTION |
|----------|------|-------------|-----------------------------|
| 1 | 1 | 55513 | R/H OVER-AXLE PIPE ASSEMBLY |
| 2 | 1 | 55514 | L/H OVER-AXLE PIPE ASSEMBLY |
| 3 | 1 | 55295 | R/H MUFFLER ASSEMBLY |
| 4 | 1 | 55299 | L/H MUFFLER ASSEMBLY |
| 5 | 2 | 90116 | S/S ACCUSEAL CLAMP Ø2.75 |
| 6 | 2 | 22051 | CLIP-ON NUT: M8 X 1.25mm |
| 7 | 4 | 92010 | WASHER: FLAT, M10 |

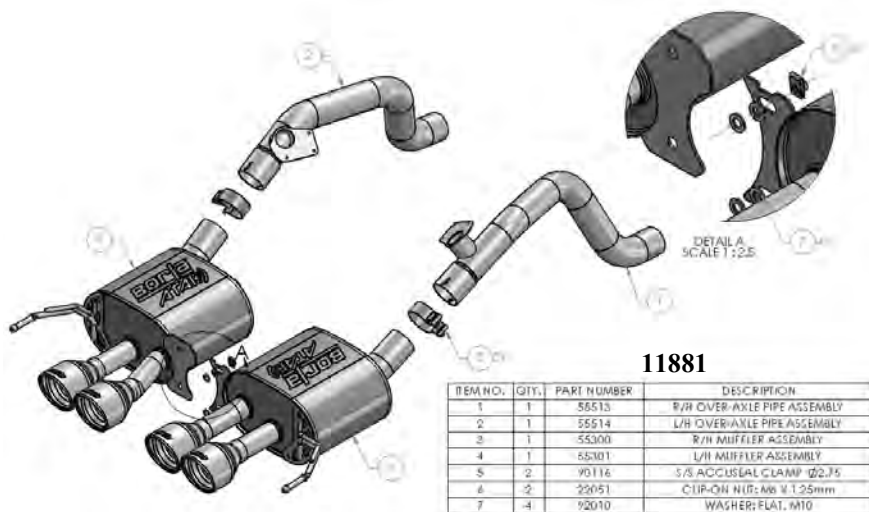

11881

| ITEM NO. | QTY. | PART NUMBER | DESCRIPTION |
|----------|------|-------------|-----------------------------|
| 1 | 1 | 55513 | R/H OVER-AXLE PIPE ASSEMBLY |
| 2 | 1 | 55514 | L/H OVER-AXLE PIPE ASSEMBLY |
| 3 | 1 | 55300 | R/H MUFFLER ASSEMBLY |
| 4 | 1 | 55301 | L/H MUFFLER ASSEMBLY |
| 5 | 2 | 90116 | S/S ACCUSEAL CLAMP Ø2.75 |
| 6 | 2 | 22051 | CLIP-ON NUT: M8 X 1.25mm |
| 7 | 4 | 92010 | WASHER: FLAT, M10 |

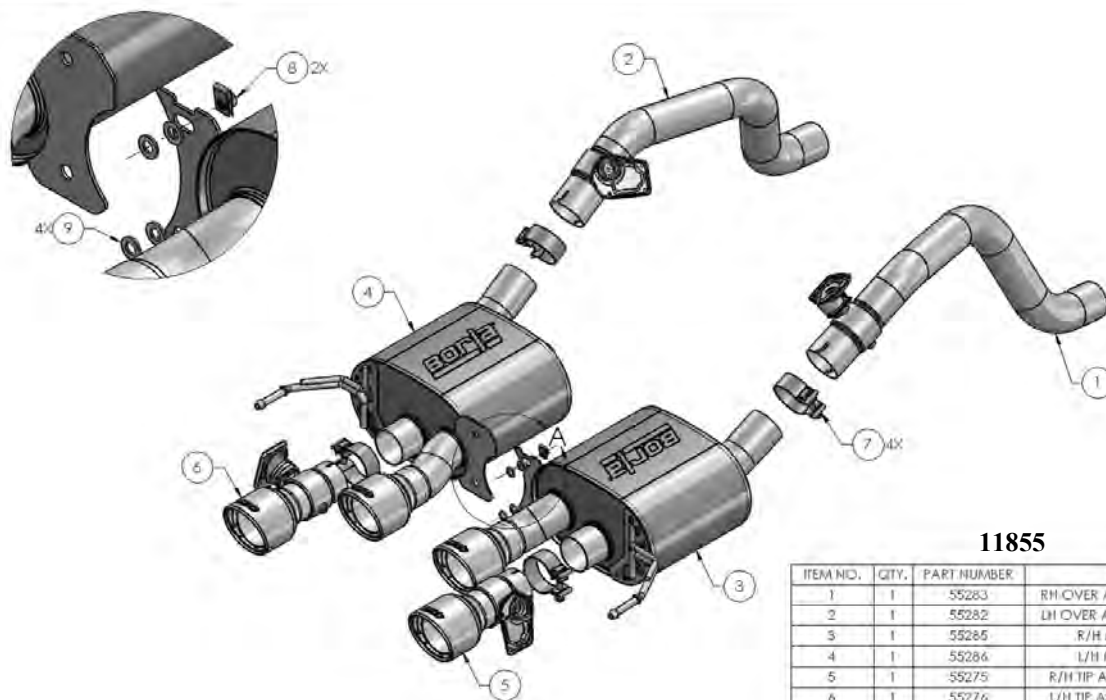

11855

| ITEM NO. | QTY. | PART NUMBER | DESCRIPTION |
|----------|------|-------------|-------------------------------|
| 1 | 1 | 55283 | RH OVER AXLE TUBE W/AFM VALVE |
| 2 | 1 | 55282 | LH OVER AXLE TUBE W/AFM VALVE |
| 3 | 1 | 55285 | R/H MUFFLER ASSEMBLY |
| 4 | 1 | 55286 | L/H MUFFLER ASSEMBLY |
| 5 | 1 | 55275 | R/H TIP ASSEMBLY W/NPP VALVE |
| 6 | 1 | 55276 | L/H TIP ASSEMBLY W/NPP VALVE |
| 7 | 4 | 90116 | S/S ACCUSEAL CLAMP Ø2.75 |
| 8 | 2 | 22051 | CLIP-ON NUT: MB X 1.25mm |
| 9 | 4 | 92010 | WASHER: FLAT, M10 |

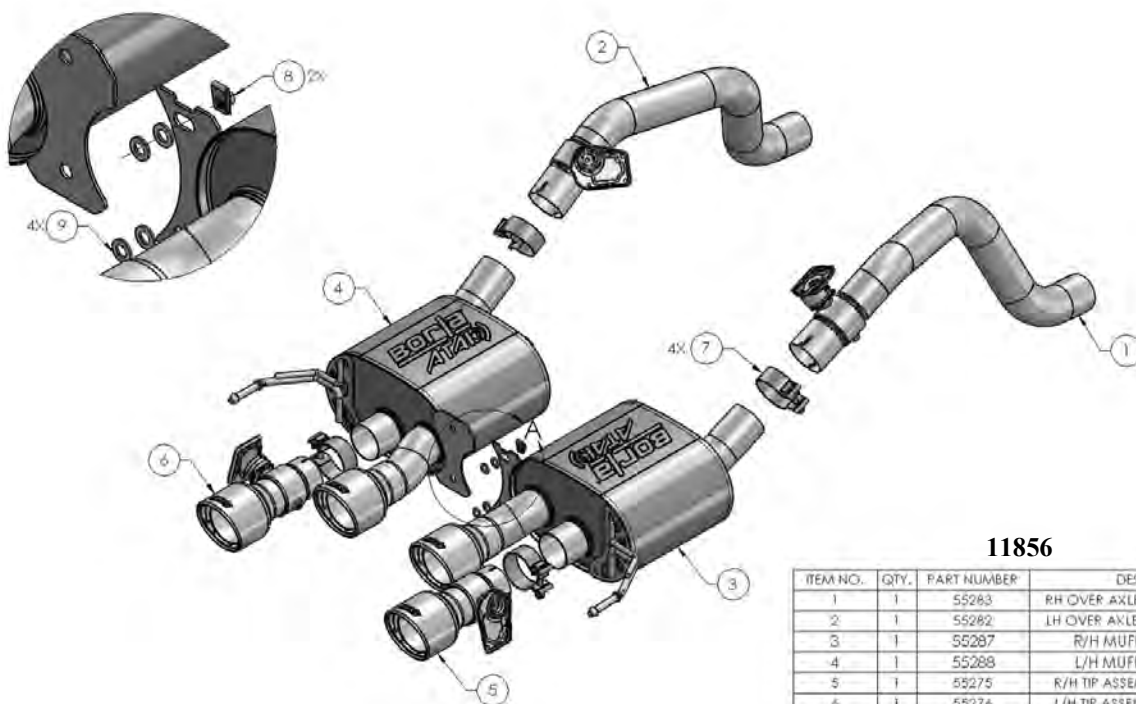

11856

| ITEM NO. | QTY. | PART NUMBER | DESCRIPTION |
|----------|------|-------------|-------------------------------|
| 1 | 1 | 55283 | RH OVER AXLE TUBE W/AFM VALVE |
| 2 | 1 | 55282 | LH OVER AXLE TUBE W/AFM VALVE |
| 3 | 1 | 55287 | R/H MUFFLER ASSEMBLY |
| 4 | 1 | 55288 | L/H MUFFLER ASSEMBLY |
| 5 | 1 | 55275 | R/H TIP ASSEMBLY W/NPP VALVE |
| 6 | 1 | 55276 | L/H TIP ASSEMBLY W/NPP VALVE |
| 7 | 4 | 90116 | S/S ACCUSEAL CLAMP Ø2.75 |
| 8 | 2 | 22051 | CLIP-ON NUT: MB X 1.25mm |
| 9 | 4 | 92010 | WASHER: FLAT, M10 |

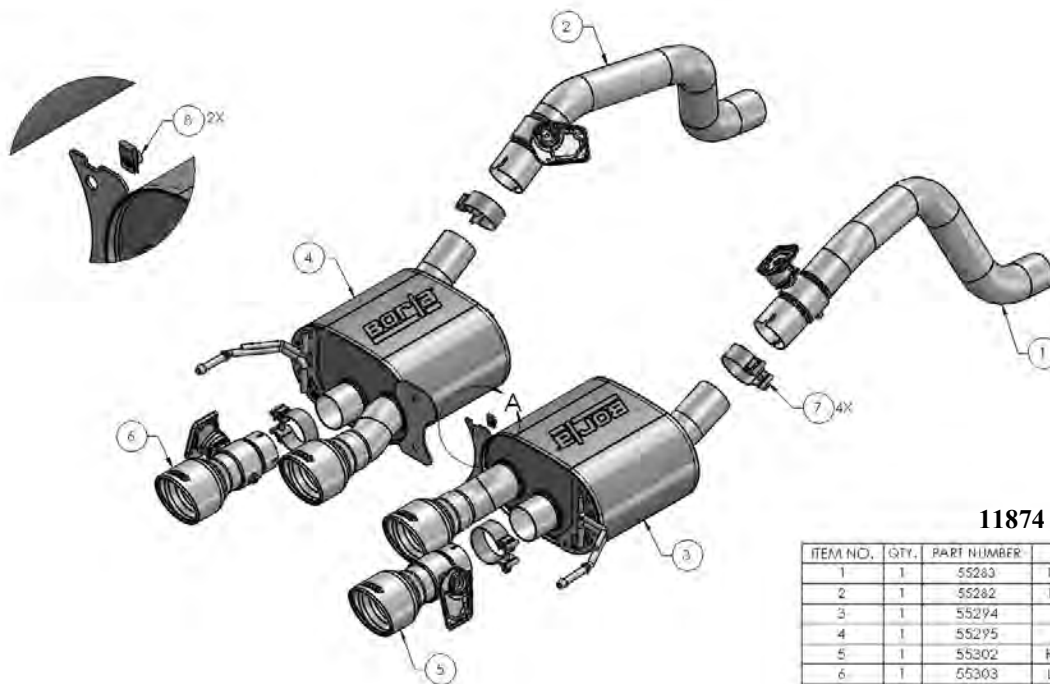

11874

| ITEM NO. | QTY. | PART NUMBER | DESCRIPTION |
|----------|------|-------------|-------------------------------|
| 1 | 1 | 55283 | RH OVER AXLE TUBE W/AFM VALVE |
| 2 | 1 | 55282 | LH OVER AXLE TUBE W/AFM VALVE |
| 3 | 1 | 55294 | R/H MUFFLER ASSEMBLY |
| 4 | 1 | 55295 | L/H MUFFLER ASSEMBLY |
| 5 | 1 | 55302 | R/H TIP ASSEMBLY W/NPP VALVE |
| 6 | 1 | 55303 | L/H TIP ASSEMBLY W/NPP VALVE |
| 7 | 4 | 90116 | S/S ACCUSEAL CLAMP Ø2.75 |
| 8 | 2 | 22051 | CLIP-ON NUT: M8 X 1.25mm |

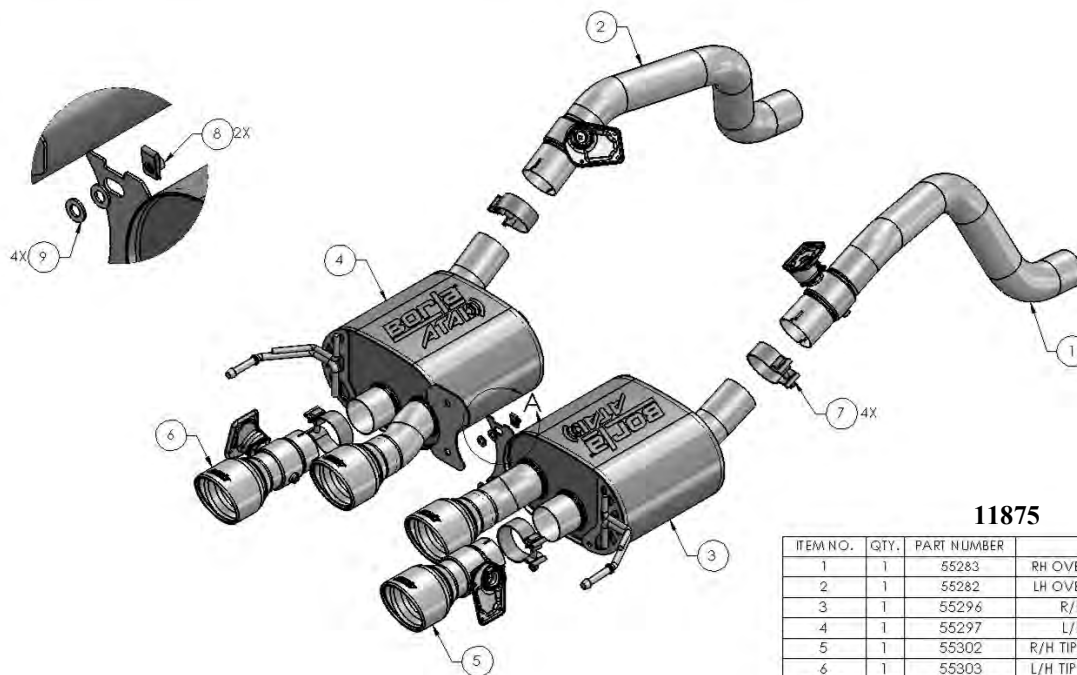

11875

| ITEM NO. | QTY. | PART NUMBER | DESCRIPTION |
|----------|------|-------------|-------------------------------|
| 1 | 1 | 55283 | RH OVER AXLE TUBE W/AFM VALVE |
| 2 | 1 | 55282 | LH OVER AXLE TUBE W/AFM VALVE |
| 3 | 1 | 55296 | R/H MUFFLER ASSEMBLY |
| 4 | 1 | 55297 | L/H MUFFLER ASSEMBLY |
| 5 | 1 | 55302 | R/H TIP ASSEMBLY W/NPP VALVE |
| 6 | 1 | 55303 | L/H TIP ASSEMBLY W/NPP VALVE |
| 7 | 4 | 90116 | S/S ACCUSEAL CLAMP Ø2.75 |
| 8 | 2 | 22051 | CLIP-ON NUT: M8 X 1.25mm |
| 9 | 4 | 92010 | WASHER: FLAT, M10 |

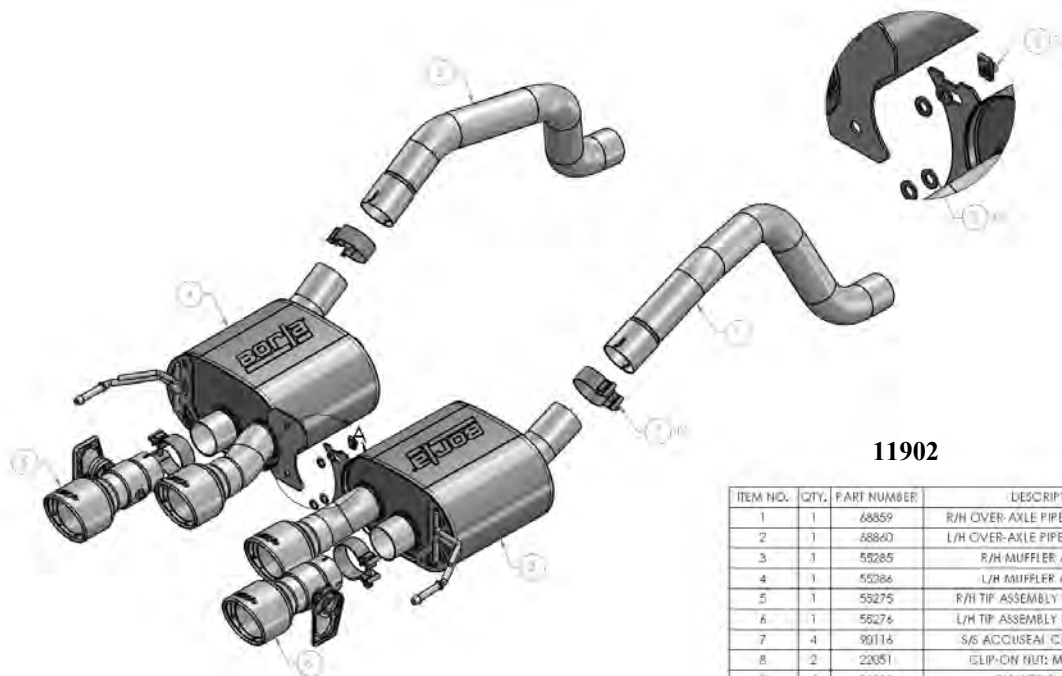

11902

| ITEM NO. | QTY. | PART NUMBER | DESCRIPTION |
|----------|------|-------------|------------------------------------|
| 1 | 1 | 68859 | R/H OVER-AXLE PIPE: Ø2.75 X 34.34" |
| 2 | 1 | 68840 | L/H OVER-AXLE PIPE: Ø2.75 X 33.65" |
| 3 | 1 | 55285 | R/H MUFFLER ASSEMBLY |
| 4 | 1 | 55286 | L/H MUFFLER ASSEMBLY |
| 5 | 1 | 55275 | R/H TIP ASSEMBLY W/NPP VALVE |
| 6 | 1 | 55276 | L/H TIP ASSEMBLY W/NPP VALVE |
| 7 | 4 | 90116 | S/S ACCUSEAL CLAMP: Ø2.75 |
| 8 | 2 | 22051 | CLIP-ON NUT: M8 X 1.25mm |
| 9 | 4 | 92010 | WASHER: FLAT, M10 |

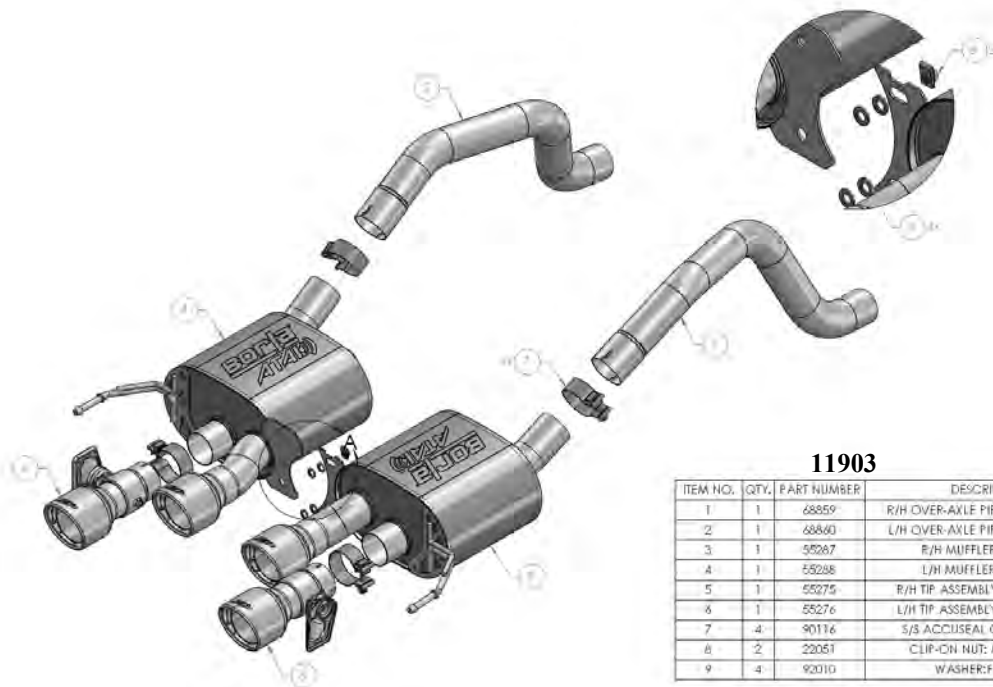

11903

| ITEM NO. | QTY. | PART NUMBER | DESCRIPTION |
|----------|------|-------------|------------------------------------|
| 1 | 1 | 68859 | R/H OVER-AXLE PIPE: Ø2.75 X 34.34" |
| 2 | 1 | 68840 | L/H OVER-AXLE PIPE: Ø2.75 X 33.65" |
| 3 | 1 | 55287 | R/H MUFFLER ASSEMBLY |
| 4 | 1 | 55288 | L/H MUFFLER ASSEMBLY |
| 5 | 1 | 55275 | R/H TIP ASSEMBLY W/NPP VALVE |
| 6 | 1 | 55276 | L/H TIP ASSEMBLY W/NPP VALVE |
| 7 | 4 | 90116 | S/S ACCUSEAL CLAMP: Ø2.75 |
| 8 | 2 | 22051 | CLIP-ON NUT: M8 X 1.25mm |
| 9 | 4 | 92010 | WASHER: FLAT, M10 |

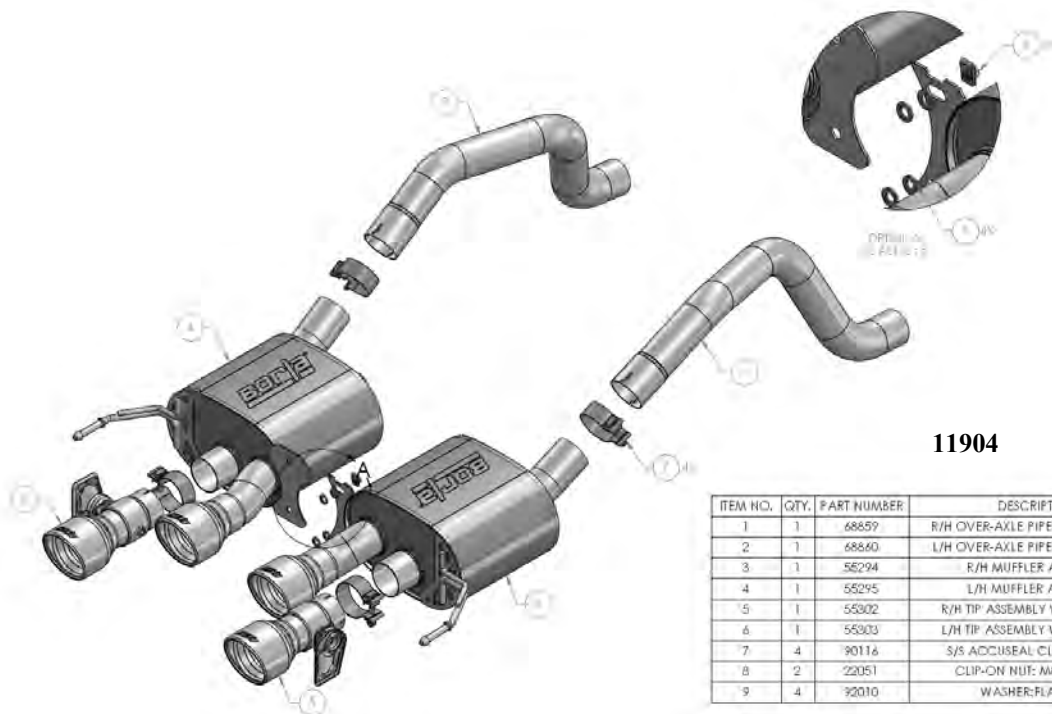

11904

| ITEM NO. | QTY. | PART NUMBER | DESCRIPTION |
|----------|------|-------------|------------------------------------|
| 1 | 1 | 68859 | R/H OVER-AXLE PIPE: Ø2.75 X 34.34" |
| 2 | 1 | 68860 | L/H OVER-AXLE PIPE: Ø2.75 X 33.65" |
| 3 | 1 | 55294 | R/H MUFFLER ASSEMBLY |
| 4 | 1 | 55295 | L/H MUFFLER ASSEMBLY |
| 5 | 1 | 55302 | R/H TIP ASSEMBLY W/NIPP VALVE |
| 6 | 1 | 55303 | L/H TIP ASSEMBLY W/NIPP VALVE |
| 7 | 4 | 90116 | S/S ACCUSEAL CLAMP: Ø2.75 |
| 8 | 2 | 22051 | CLIP-ON NUT: M8 X 1.25mm |
| 9 | 4 | 92010 | WASHER:FLAT, M10 |

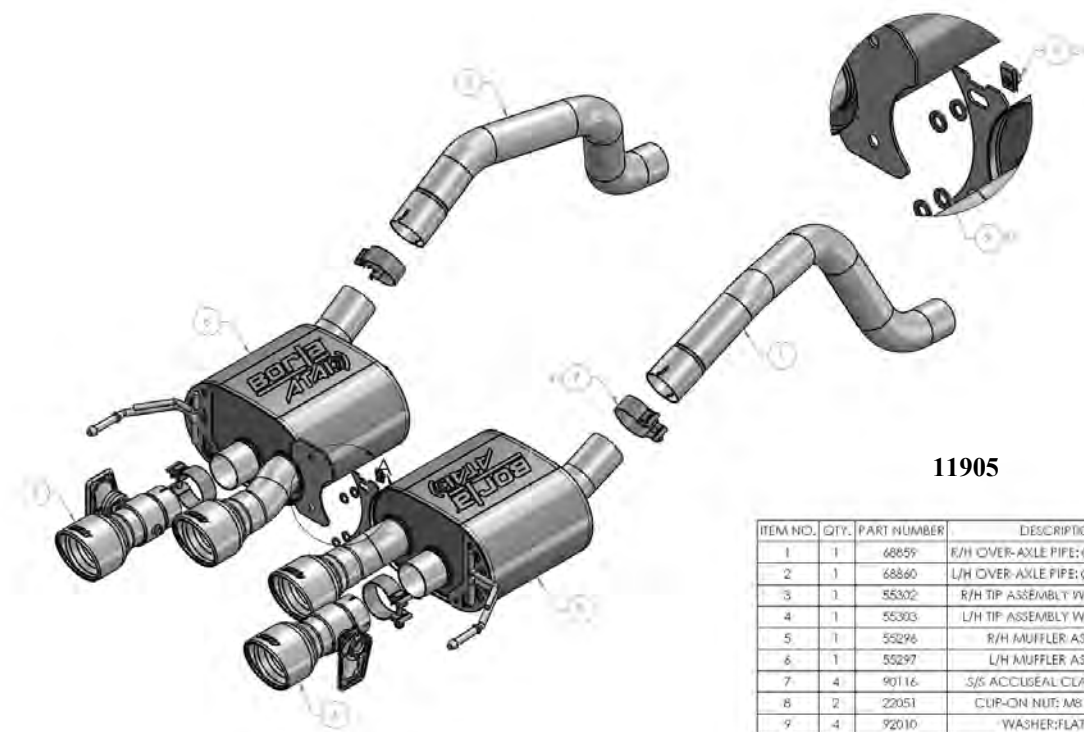

11905

| ITEM NO. | QTY. | PART NUMBER | DESCRIPTION |
|----------|------|-------------|------------------------------------|
| 1 | 1 | 68859 | R/H OVER-AXLE PIPE: Ø2.75 X 34.34" |
| 2 | 1 | 68860 | L/H OVER-AXLE PIPE: Ø2.75 X 33.65" |
| 3 | 1 | 55302 | R/H TIP ASSEMBLY W/NIPP VALVE |
| 4 | 1 | 55303 | L/H TIP ASSEMBLY W/NIPP VALVE |
| 5 | 1 | 55296 | R/H MUFFLER ASSEMBLY |
| 6 | 1 | 55297 | L/H MUFFLER ASSEMBLY |
| 7 | 4 | 90116 | S/S ACCUSEAL CLAMP: Ø2.75 |
| 8 | 2 | 22051 | CLIP-ON NUT: M8 X 1.25mm |
| 9 | 4 | 92010 | WASHER:FLAT, M10 |

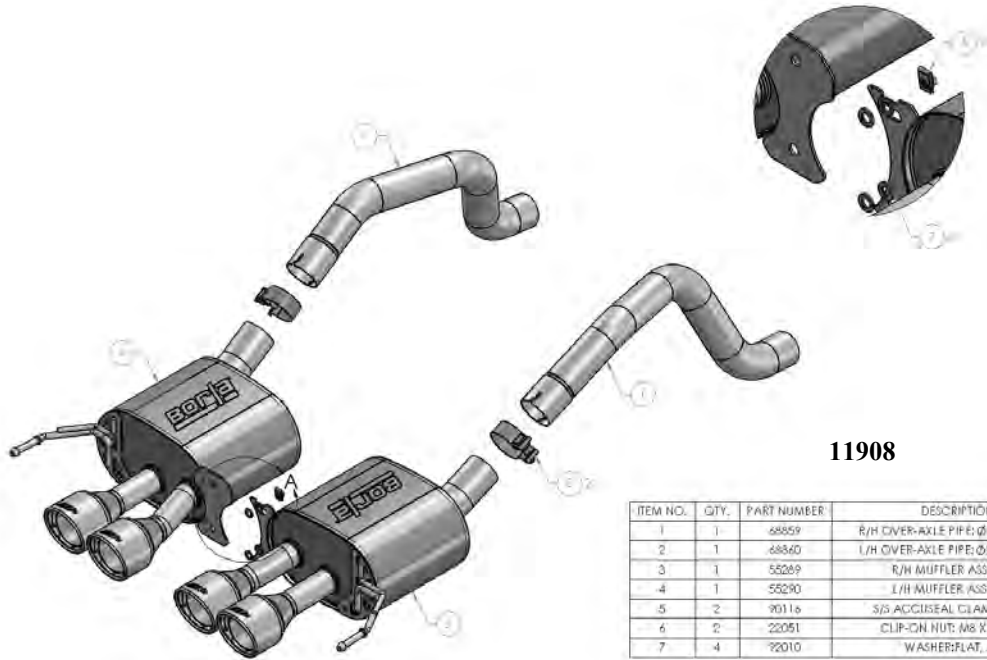

11908

| ITEM NO. | QTY. | PART NUMBER | DESCRIPTION |
|----------|------|-------------|------------------------------------|
| 1 | 1 | 68859 | R/H OVER-AXLE PIPE: Ø2.75 X 34.34" |
| 2 | 1 | 68860 | L/H OVER-AXLE PIPE: Ø2.75 X 33.65" |
| 3 | 1 | 55289 | R/H MUFFLER ASSEMBLY |
| 4 | 1 | 55290 | L/H MUFFLER ASSEMBLY |
| 5 | 2 | 90116 | S/S ACCESSAL CLAMP: Ø2.75 |
| 6 | 2 | 22051 | CLIP-ON NUT: M8 X 1.25mm |
| 7 | 4 | 92010 | WASHER/PLAT, M10 |

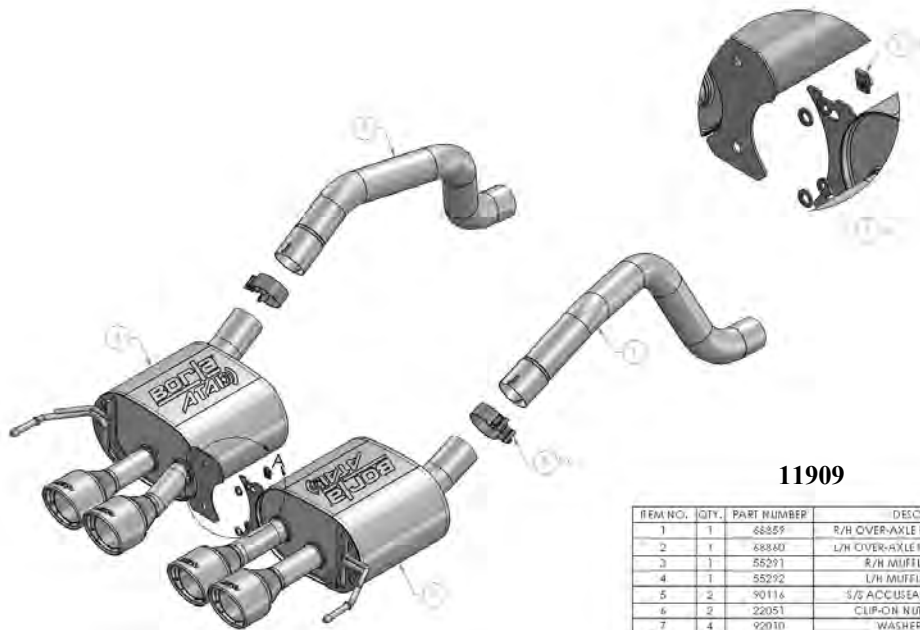

11909

| ITEM NO. | QTY. | PART NUMBER | DESCRIPTION |
|----------|------|-------------|------------------------------------|
| 1 | 1 | 68859 | R/H OVER-AXLE PIPE: Ø2.75 X 34.34" |
| 2 | 1 | 68860 | L/H OVER-AXLE PIPE: Ø2.75 X 33.65" |
| 3 | 1 | 55291 | R/H MUFFLER ASSEMBLY |
| 4 | 1 | 55292 | L/H MUFFLER ASSEMBLY |
| 5 | 2 | 90116 | S/S ACCESSAL CLAMP: Ø2.75 |
| 6 | 2 | 22051 | CLIP-ON NUT: M8 X 1.25mm |
| 7 | 4 | 92010 | WASHER/PLAT, M10 |

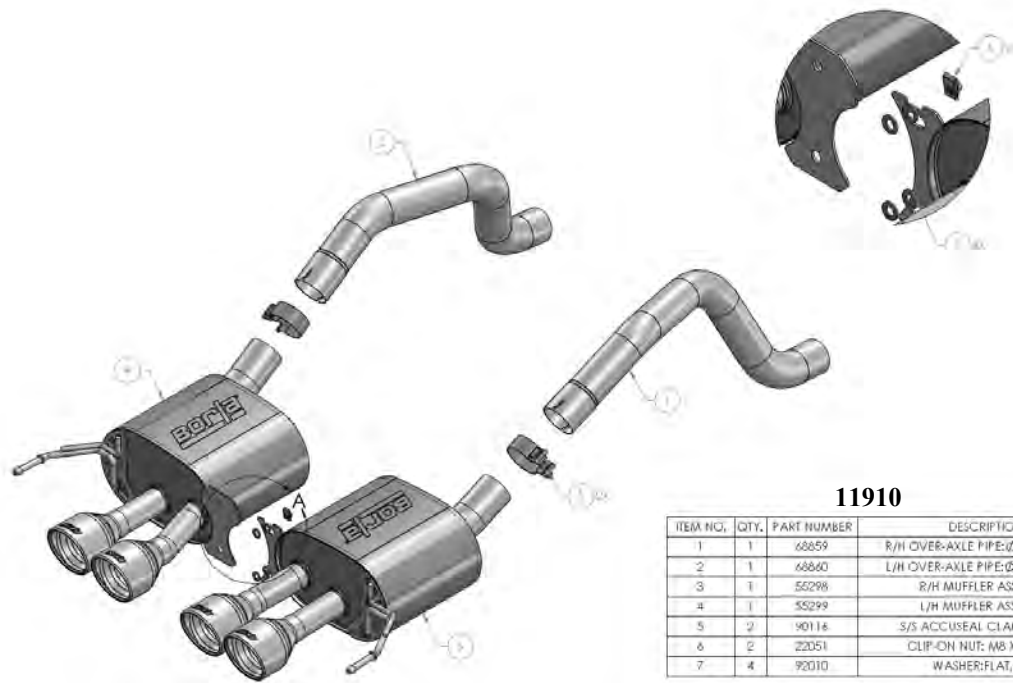

11910

| ITEM NO. | QTY. | PART NUMBER | DESCRIPTION |
|----------|------|-------------|-----------------------------------|
| 1 | 1 | 68859 | R/H OVER-AXLE PIPE:Ø2.75 X 34.34" |
| 2 | 1 | 68860 | L/H OVER-AXLE PIPE:Ø2.75 X 33.65" |
| 3 | 1 | 55298 | R/H MUFFLER ASSEMBLY |
| 4 | 1 | 55299 | L/H MUFFLER ASSEMBLY |
| 5 | 2 | 90116 | S/S ACCUSEAL CLAMP: Ø2.75 |
| 6 | 2 | 22051 | CLIP-ON NUT: M8 X 1.25mm |
| 7 | 4 | 92010 | WASHER:FLAT, M10 |

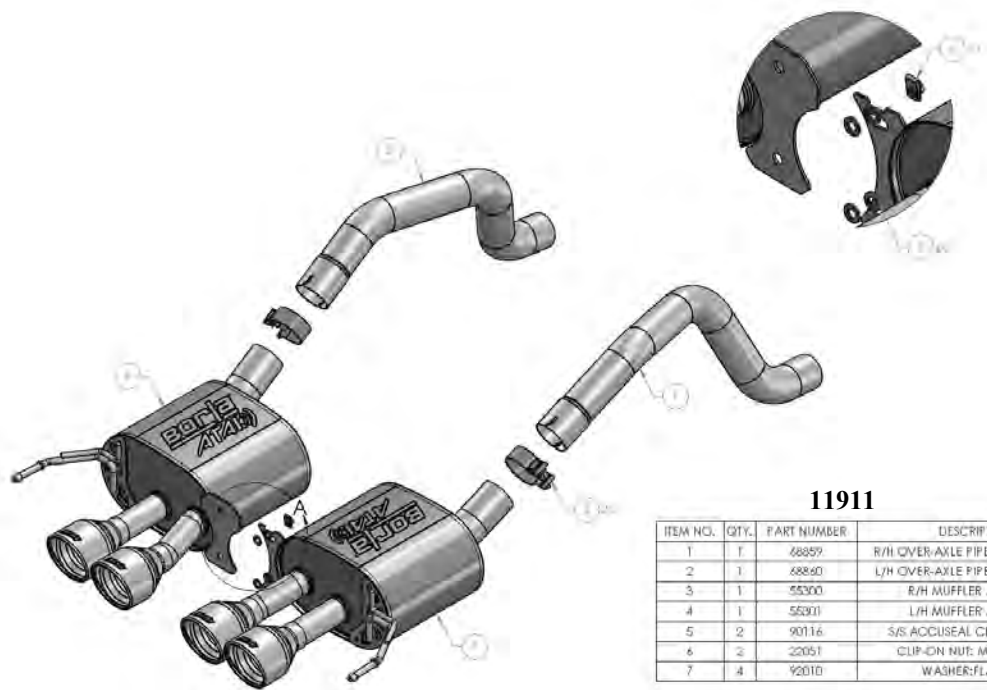

11911

| ITEM NO. | QTY. | PART NUMBER | DESCRIPTION |
|----------|------|-------------|-----------------------------------|
| 1 | 1 | 68859 | R/H OVER-AXLE PIPE:Ø2.75 X 34.34" |
| 2 | 1 | 68860 | L/H OVER-AXLE PIPE:Ø2.75 X 33.65" |
| 3 | 1 | 55300 | R/H MUFFLER ASSEMBLY |
| 4 | 1 | 55301 | L/H MUFFLER ASSEMBLY |
| 5 | 2 | 90116 | S/S ACCUSEAL CLAMP: Ø2.75 |
| 6 | 2 | 22051 | CLIP-ON NUT: M8 X 1.25mm |
| 7 | 4 | 92010 | WASHER:FLAT, M10 |

Caution!!! Never work on a hot exhaust system. Serious injury in the form of burns can result if the vehicle has been in use and the exhaust system is hot, allow vehicle to cool for at least 1 hour. Always wear eye protection when working under any vehicle.

Note: It is our recommendation that you use a hoist or hydraulic lift to facilitate the installation of your new Borla Performance Exhaust System.

Taking all under car safety precautions, lift the vehicle using a hoist or hydraulic lift. Once this has been done, you may begin the removal of your old exhaust system from your vehicle.

Note: Before removing the original exhaust system from your vehicle, please compare the parts you have received with the bill of materials provided on the previous page to assure that you have all the parts necessary for the installation of your new Borla Performance Exhaust System.

Note: With a used vehicle, we suggest a penetrating spray lubricant to be applied liberally to all exhaust fasteners and allowing a significant period of time for the chemical to lubricate the threads before attempting to disassemble.

Original Exhaust System Removal

1. REAR VALENCE MUST BE REMOVED TO REMOVE FACTORY EXHAUST AND INSTALL YOUR NEW BORLA REAR SECTION. KEEP ALL HARDWARE FOR REINSTALLATION.
2. Remove rear license plate from vehicle.
3. Remove (5) 7mm bolts on right-side rear valence. (See Fig. 1)
4. Repeat step 2 on left-side bolt-removal on valence.
5. Remove (2) 10mm bolts above exhaust tips. (See Fig. 2)
6. Valence is fastened from the backside with molded-in plastic tabs. Release (6) tabs from the backside of the valence by gentle pulling tab from valence working the right-side first. Repeat for (6) left-side tabs. (See Fig. 3)
7. Carefully remove left and right reflectors. Note and mark Left and Right sides before placing aside for reinstallation. (See Fig. 4)
8. Remove (6) 10mm bolts from valence top. Carefully release tabs on top of valence from vehicle. (See Fig. 5)
9. With help from assistant, carefully remove valence (protecting painted surfaces) and keep with removed hardware in a for reinstallation later.

Warning: Use extreme caution during installation. Torque all fasteners according to manufacturer's torque values and tightening sequence. DO NOT use air impact tools to tighten fasteners on Borla Performance Exhaust Systems. Use of such tools may result in bent flanges or gasket contact areas leading to exhaust leaks.



Figure 1

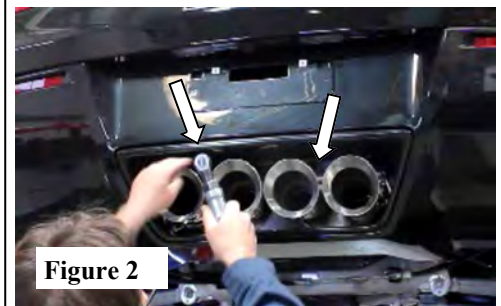

Figure 2



Figure 3



Figure 4



Figure 5

Caution!!! *Never work on a hot exhaust system. Serious injury in the form of burns can result if the vehicle has been in use and the exhaust system is hot, allow vehicle to cool for at least 1 hour. Always wear eye protection when working under any vehicle.*

Note: It is our recommendation that you use a hoist or hydraulic lift to facilitate the installation of your new Borla Performance Exhaust System.

Taking all under car safety precautions, lift the vehicle using a hoist or hydraulic lift. Once this has been done, you may begin the removal of your old exhaust system from your vehicle.

Note: Before removing the original exhaust system from your vehicle, please compare the parts you have received with the bill of materials provided on the previous page to assure that you have all the parts necessary for the installation of your new Borla Performance Exhaust System.

Note: With a used vehicle, we suggest a penetrating spray lubricant to be applied liberally to all exhaust fasteners and allowing a significant period of time for the chemical to lubricate the threads before attempting to disassemble.

Original Exhaust System Removal (continued)

10. Loosen and remove bolts holding Tunnel Stiffening Brace using 13mm and 15mm sockets. *Note (2) keyhole-slots in the middle of the brace. Loosen (do not remove these bolts) and carefully slide brace rearwards and remove. Keep for reinstallation later.* (See Fig. 6)
11. Loosen and remove flange bolts at front of mid-pipe. Keep hardware for reinstallation late. (See Fig. 7)
12. Loosen and remove 13mm bolts at rear of mid-pipe. Loosen (2) 15mm clamp nuts at rear of mid-pipe (do not remove clamps). (See Fig. 8)
13. Carefully remove mid-pipe from vehicle. Keep for reinstallation later. (See Fig. 9)
14. On vehicle equipped with rear electronic valves (NPP option), disconnect wire harness on left and right sides by pulling pin and sliding out of electronic assembly. (See Fig. 10)
15. *On vehicles equipped with Automatic Transmission, disconnect driver's side shift linkage from transmission. This allows access removing over axle pipe.*

Warning: *Use extreme caution during installation. Torque all fasteners according to manufacturer's torque values and tightening sequence. DO NOT use air impact tools to tighten fasteners on Borla Performance Exhaust Systems. Use of such tools may result in bent flanges or gasket contact areas leading to exhaust leaks.*

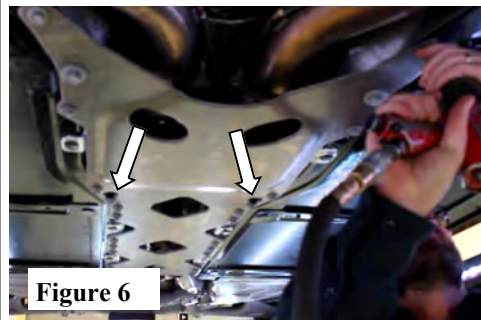

Figure 6

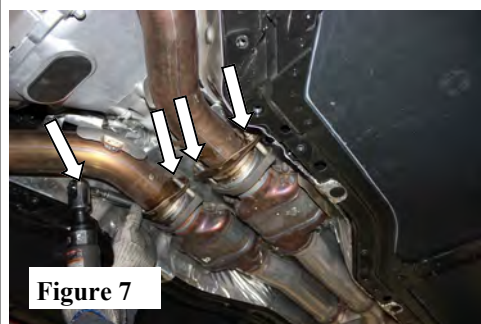

Figure 7

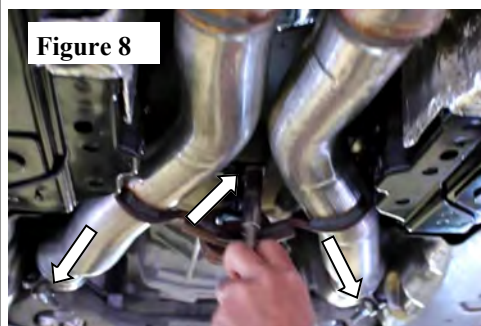

Figure 8



Figure 9

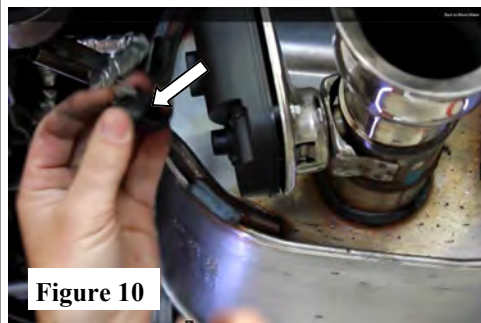

Figure 10

Caution!!! Never work on a hot exhaust system. Serious injury in the form of burns can result if the vehicle has been in use and the exhaust system is hot, allow vehicle to cool for at least 1 hour. Always wear eye protection when working under any vehicle.

Note: It is our recommendation that you use a hoist or hydraulic lift to facilitate the installation of your new Borla Performance Exhaust System.

Taking all under car safety precautions, lift the vehicle using a hoist or hydraulic lift. Once this has been done, you may begin the removal of your old exhaust system from your vehicle.

Note: Before removing the original exhaust system from your vehicle, please compare the parts you have received with the bill of materials provided on the previous page to assure that you have all the parts necessary for the installation of your new Borla Performance Exhaust System.

Note: With a used vehicle, we suggest a penetrating spray lubricant to be applied liberally to all exhaust fasteners and allowing a significant period of time for the chemical to lubricate the threads before attempting to disassemble.

Original Exhaust System Removal (continued)

16. Support rear mufflers with support stands or assistant. Loosen and remove (2) bolts on center bracket holding mufflers together. Loosen and remove (4) 13mm bolts from hangar brackets. (See Fig. 10)
17. Lower left-side muffler and disconnect AFM wire harness by pulling pin and sliding out from electronic assembly. (See Fig. 11)
18. Repeat step 16 for right-side AFM harness.
19. Remove left and right-side rear mufflers from vehicle.

Warning: Use extreme caution during installation. Torque all fasteners according to manufacturer's torque values and tightening sequence. DO NOT use air impact tools to tighten fasteners on Borla Performance Exhaust Systems. Use of such tools may result in bent flanges or gasket contact areas leading to exhaust leaks.



Figure 10

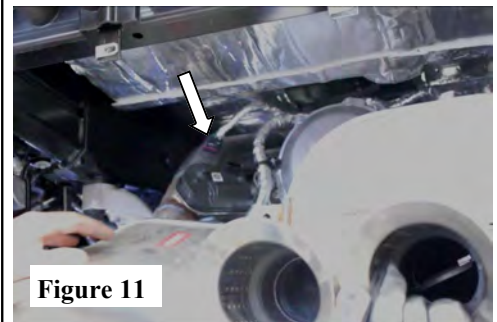

Figure 11



Figure 12

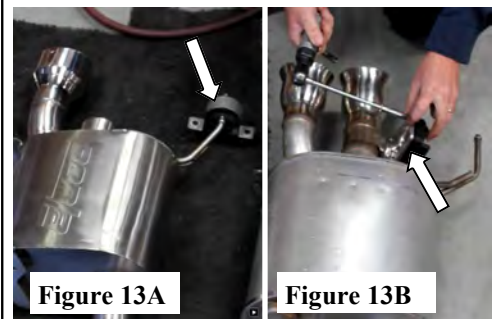

Figure 13A

Figure 13B



Figure 14

Caution!!! Never work on a hot exhaust system. Serious injury in the form of burns can result if the vehicle has been in use and the exhaust system is hot, allow vehicle to cool for at least 1 hour. Always wear eye protection when working under any vehicle.

Note: It is our recommendation that you use a hoist or hydraulic lift to facilitate the installation of your new Borla Performance Exhaust System.

Taking all under car safety precautions, lift the vehicle using a hoist or hydraulic lift. Once this has been done, you may begin the removal of your old exhaust system from your vehicle.

Note: Before removing the original exhaust system from your vehicle, please compare the parts you have received with the bill of materials provided on the previous page to assure that you have all the parts necessary for the installation of your new Borla Performance Exhaust System.

Borla Performance Exhaust Installation

1. On a flat surface place **L/H Muffler Assembly** next to factory LH muffler. Transfer rubber isolator assembly to LH Muffler Assembly. (See Fig. 13A)
2. On vehicles equipped with rear electronic valves (NPP option), remove electronic assembly using an 8mm socket and transfer electronic assembly to **L/H Muffler Assembly**. (See Figs. 13B & 14)
3. On front of L/H factory muffler assembly, remove AFM electronic assembly using an 8mm socket and transfer electronic assembly to **L/H Over-Axle Tube w/ AFM Valve**. (See Figs. 15 & 16)
4. Repeat steps 1-3 for R/H Muffler Assembly.
5. On flat surface orient **R/H Muffler Assembly** and **R/H Over-Axle Tube w/ AFM Valve**. Place clamp over **R/H Muffler Assembly** inlet making sure to orient nut indicated by arrow. (See Fig. 17)
6. Insert **R/H Over-Axle Tube w/ AFM Valve** over inlet of **R/H Muffler Assembly**. Position clamp over notches and lightly lighten nut.
7. Repeat steps 5-6 for **L/H Muffler Assembly** and **L/H Over-Axle Tube w/ AFM Valve**.

Note: When you first start your vehicle after the installation of your new Borla Performance Exhaust System, there may be some smoke and fumes coming from the system. This is a protective oil based coating used in the manufacturing of mandrel bent performance exhaust tubing. This is not a problem and will disappear within a very short period of time after the exhaust has reached normal operating temperatures.

Warning: Use extreme caution during installation. Torque all fasteners according to manufacturer's torque values and tightening sequence. DO NOT use air impact tools to tighten fasteners on Borla Performance Exhaust Systems. Use of such tools may result in bent flanges or gasket contact areas leading to exhaust leaks.

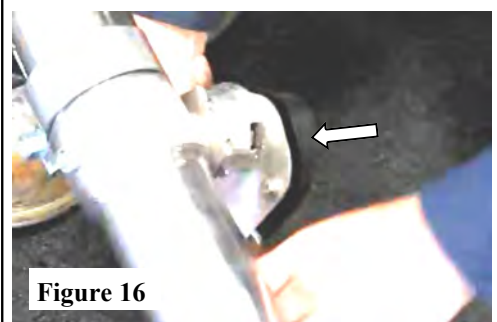
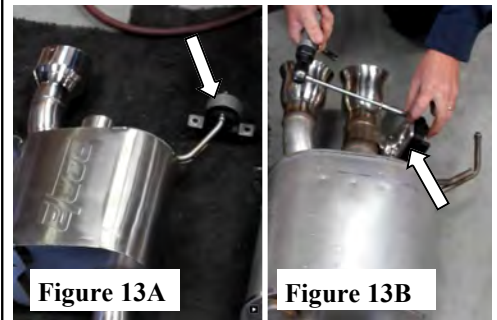

Caution!!! Never work on a hot exhaust system. Serious injury in the form of burns can result if the vehicle has been in use and the exhaust system is hot, allow vehicle to cool for at least 1 hour. Always wear eye protection when working under any vehicle.

Note: It is our recommendation that you use a hoist or hydraulic lift to facilitate the installation of your new Borla Performance Exhaust System.

Taking all under car safety precautions, lift the vehicle using a hoist or hydraulic lift. Once this has been done, you may begin the removal of your old exhaust system from your vehicle.

Note: Before removing the original exhaust system from your vehicle, please compare the parts you have received with the bill of materials provided on the previous page to assure that you have all the parts necessary for the installation of your new Borla Performance Exhaust System.

Borla Performance Exhaust Installation (continued)

8. Snap in (2) **Clip-On Nuts** into center bracket of **R/H Muffler Assembly**. (See Fig. 18)
9. Starting with completed right-side assembly, insert Over Axle inlet tube to vehicle. (See Fig. 19)
10. Connect wiring harness to AFM valve. (See Fig. 20)
11. Insert (2) factory bolts to rubber isolator assembly. DO NOT TIGHTEN BOLTS. (See Fig. 21)
12. Repeat steps 9-11 for completed left-side assembly.
13. Align brackets on mufflers with the Clip-On Nuts on R/H Muffler bracket positioned behind the L/H Muffler bracket.
14. Starting with factory upper bolt, insert through upper R/H muffler center bracket hole, through provided shim **M10 Washers** (use 1 or both as needed to align tip alignment), then thread into Clip-On Nut. DO NOT TIGHTEN BOLTS. (See Fig. 22)
15. Repeat step 14 for lower factory bolt.

Note: When you first start your vehicle after the installation of your new Borla Performance Exhaust System, there may be some smoke and fumes coming from the system. This is a protective oil based coating used in the manufacturing of mandrel bent performance exhaust tubing. This is not a problem and will disappear within a very short period of time after the exhaust has reached normal operating temperatures.

Warning: Use extreme caution during installation. Torque all fasteners according to manufacturer's torque values and tightening sequence. DO NOT use air impact tools to tighten fasteners on Borla Performance Exhaust Systems. Use of such tools may result in bent flanges or gasket contact areas leading to exhaust leaks.



Figure 18

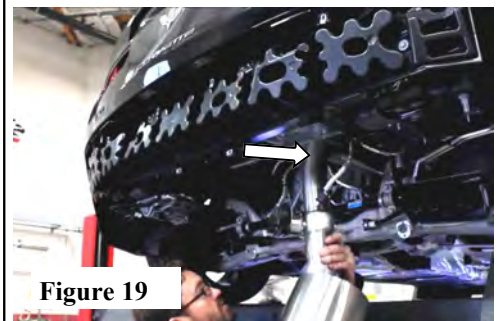

Figure 19



Figure 20



Figure 21

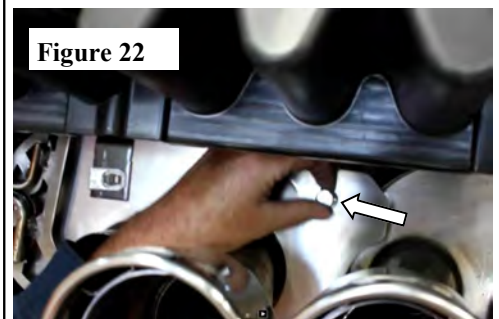

Figure 22

Caution!!! Never work on a hot exhaust system. Serious injury in the form of burns can result if the vehicle has been in use and the exhaust system is hot, allow vehicle to cool for at least 1 hour. Always wear eye protection when working under any vehicle.

Note: It is our recommendation that you use a hoist or hydraulic lift to facilitate the installation of your new Borla Performance Exhaust System.

Taking all under car safety precautions, lift the vehicle using a hoist or hydraulic lift. Once this has been done, you may begin the removal of your old exhaust system from your vehicle.

Note: Before removing the original exhaust system from your vehicle, please compare the parts you have received with the bill of materials provided on the previous page to assure that you have all the parts necessary for the installation of your new Borla Performance Exhaust System.

Borla Performance Exhaust Installation (continued)

16. With help from an assistant, reinstall the factory mid-pipe inserting the outlets first then aligning the front-flanges to the factory cat-pipe. (See Fig. 23)
17. Use factory hardware to connect the front-flanges and rear hangars to vehicle. Begin tightening bolts at rear hangar making sure the mid-pipe is level. Tighten front-flanges hardware to factory specs making sure the flanges remain parallel. (See Fig. 24)
18. Before tightening over axle clamps, push both Over Axle Tubes forward to verify tube seating into mid-pipe. Position clamp bolt between Over Axle Tube notches and lightly tighten clamp nut with 15mm socket. Repeat for other side. (See Fig. 24)
19. With assistance hold center tips level with a .250" gap. Slowly tighten (2) bolts with a 13mm socket making sure bottom of brackets are parallel when viewed from the backside. Torque to 18 ft lbs. (See Figs. 25 & 26)

Note: When you first start your vehicle after the installation of your new Borla Performance Exhaust System, there may be some smoke and fumes coming from the system. This is a protective oil based coating used in the manufacturing of mandrel bent performance exhaust tubing. This is not a problem and will disappear within a very short period of time after the exhaust has reached normal operating temperatures.

Warning: Use extreme caution during installation. Torque all fasteners according to manufacturer's torque values and tightening sequence. DO NOT use air impact tools to tighten fasteners on Borla Performance Exhaust Systems. Use of such tools may result in bent flanges or gasket contact areas leading to exhaust leaks.

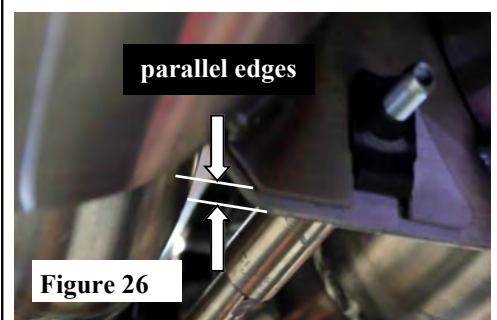
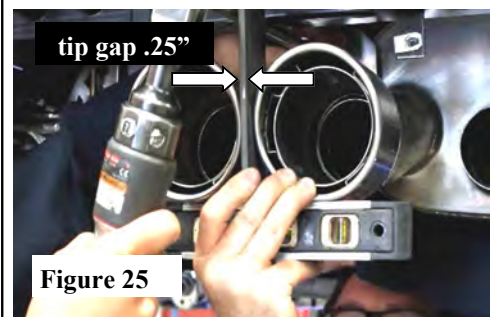

Caution!!! Never work on a hot exhaust system. Serious injury in the form of burns can result if the vehicle has been in use and the exhaust system is hot, allow vehicle to cool for at least 1 hour. Always wear eye protection when working under any vehicle.

Note: It is our recommendation that you use a hoist or hydraulic lift to facilitate the installation of your new Borla Performance Exhaust System.

Taking all under car safety precautions, lift the vehicle using a hoist or hydraulic lift. Once this has been done, you may begin the removal of your old exhaust system from your vehicle.

Note: Before removing the original exhaust system from your vehicle, please compare the parts you have received with the bill of materials provided on the previous page to assure that you have all the parts necessary for the installation of your new Borla Performance Exhaust System.

Borla Performance Exhaust Installation (continued)

20. Tighten bolts to 35-ft lbs on left and right on rubber isolator holders. (See Fig. 27)
21. Check clearance on **Over Axle Tubes** with at least .25" clearance on all sides. (See Fig. 24)
22. Position **Over Axle Tube front clamps** between notches and tighten 15mm nuts 35 ft lbs. (See Fig. 29)
23. Using a extension and universal swivel with 15mm socket, carefully tighten left side **Over Axle Tube rear clamp nut** to 35 ft-lbs. (See Fig. 30)
24. Repeat step 17 for right side clamp.
25. On **L/H Tip Assembly** place clamp on inlet. Insert tip to outside position of L/H Muffler Assembly. (See Fig. 31) *NOTE: NPP valve is shown in figure 31.*
26. Repeat step 19 for **R/H Tip Assembly**.
27. **Reconnect shift linkage to transmission (Automatic Transmission only).**

Note: When you first start your vehicle after the installation of your new Borla Performance Exhaust System, there may be some smoke and fumes coming from the system. This is a protective oil based coating used in the manufacturing of mandrel bent performance exhaust tubing. This is not a problem and will disappear within a very short period of time after the exhaust has reached normal operating temperatures.

Warning: Use extreme caution during installation. Torque all fasteners according to manufacturer's torque values and tightening sequence. DO NOT use air impact tools to tighten fasteners on Borla Performance Exhaust Systems. Use of such tools may result in bent flanges or gasket contact areas leading to exhaust leaks.



Figure 27

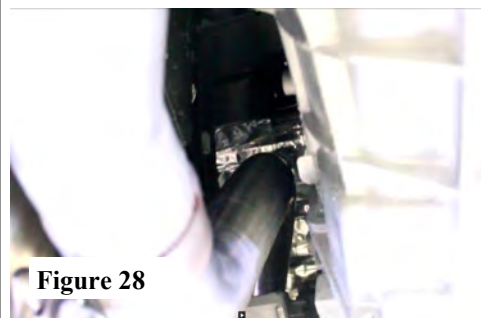

Figure 28

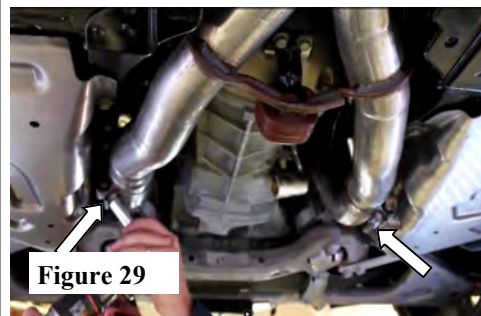

Figure 29



Figure 30



Figure 31

Caution!!! Never work on a hot exhaust system. Serious injury in the form of burns can result if the vehicle has been in use and the exhaust system is hot, allow vehicle to cool for at least 1 hour. Always wear eye protection when working under any vehicle.

Note: It is our recommendation that you use a hoist or hydraulic lift to facilitate the installation of your new Borla Performance Exhaust System.

Taking all under car safety precautions, lift the vehicle using a hoist or hydraulic lift. Once this has been done, you may begin the removal of your old exhaust system from your vehicle.

Note: Before removing the original exhaust system from your vehicle, please compare the parts you have received with the bill of materials provided on the previous page to assure that you have all the parts necessary for the installation of your new Borla Performance Exhaust System.

Borla Performance Exhaust Installation (continued)

28. Verify the tips are level using a straight-edge and tighten L/H Tip Assembly clamp bolts to 35-ft lbs on left and right on rubber isolator holders. (See Fig. 27)
29. Repeat step 25 for R/H Tip Assembly clamp bolts. (See Fig. 28)
30. Connect L/H wire harness to NPP electronic assembly. (See Fig 29)
31. Repeat step 27 to R/H wire harness.
32. With assistance of a helper carefully position the rear valence to vehicle. Insert the valence tabs starting in the top-center and moving outwards and down the sides. (See Fig. 30)
33. Thread original hardware by hand being careful not to cross-thread bolts. Tighten hardware to 5 ft lbs.
34. Replace license plate to vehicle.
35. Before starting your vehicle, make sure to check all wires, hoses, brake lines, body parts and tires for safe clearance from the exhaust system.
36. Start vehicle and check for any leaks. If any leaks are found, determine cause (such as loose or incorrectly positioned clamp) and repair as necessary.

Note: When you first start your vehicle after the installation of your new Borla Performance Exhaust System, there may be some smoke and fumes coming from the system. This is a protective oil based coating used in the manufacturing of mandrel bent performance exhaust tubing. This is not a problem and will disappear within a very short period of time after the exhaust has reached normal operating temperatures.

Warning: Use extreme caution during installation. Torque all fasteners according to manufacturer's torque values and tightening sequence. DO NOT use air impact tools to tighten fasteners on Borla Performance Exhaust Systems. Use of such tools may result in bent flanges or gasket contact areas leading to exhaust leaks.

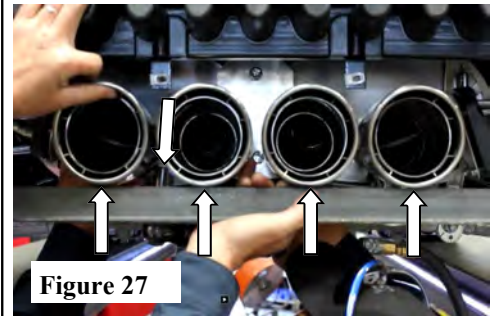

Figure 27



Figure 28

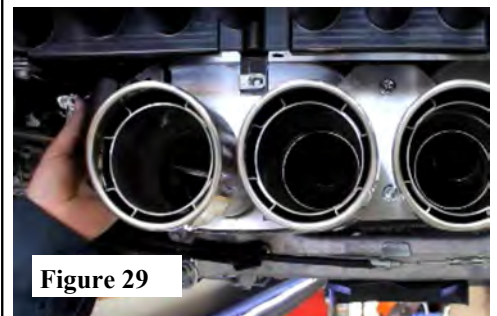

Figure 29



Figure 30



Figure 31