

## Installation for Chevrolet Corvette

### PN- 140265, 140396, 140422, 140131, 60089, 11746



**These instructions have been written to help you with the installation of your Borla Performance Exhaust System. Please read this document completely before beginning the installation of your system.**

**Please compare the parts in the box with the bill of materials provided to assure that you have all the parts necessary for this installation.**

**To ensure this part number fits your specific model year, please visit our website for the latest model year listings at [www.BORLA.com](http://www.BORLA.com).**

**Thank you for purchasing a Borla Performance Cat-Back™ Exhaust System.**

**This Borla Performance Cat-Back™ Exhaust Systems (PN-140265, 140422, 140396) are designed for the Chevrolet Corvette Z06 equipped with a 7.0L V-8 engine and manual transmissions.**

**Borla Performance Cat-Back™ Exhaust Systems (PN-140131\*) is designed for the Chevrolet Corvette C6 equipped with a 6.0L /6.2L V-8 engine, RWD coupe/convertible automatic or manual transmissions.**

*\* PN-140131 system is comprised of PN-60089 + PN-11746.*

Borla Performance Industries recommends that an exhaust shop or professional after market parts installer perform the installation of this system. However, if you decide to perform the installation on your own it is recommended that two people are used. This installation should not be performed by one person due to the risk of injury. Ensure the installers use all under car safety precautions including eye protection.

***Please take time to read and understand the following...***

By installing your Borla Performance Exhaust System, you indicate that you have read this document and you agree with the terms stated below.

It is the responsibility of the purchaser to follow all installation instruction guidelines and safety procedures supplied with your Borla Performance Exhaust System

Borla Performance Industries assumes no responsibility for damages occurring from misuse, abuse, improper installation, improper operation, lack of responsible care, or all previously stated reasons resulting from incompatibility with other manufacturer's products and/or systems.

Included with your Borla Performance Exhaust System is a warranty card. Please read it carefully before you begin any work on your vehicle. If you should have any questions regarding our warranty policy, installation, or any other matter pertaining to your new Borla Performance Exhaust System, please give us a call at the number provided on the warranty card.

**Minimum Required Tool List:**

**TOOLS:**

- 1 3/8" Drive Ratchet
- 2 3/8" Drive Extension 3"
- 3 13mm Socket
- 4 15mm Socket
- 5 Pry Bar

**SHOP SUPPLIES:**

- 1 Spray Lubricant

**Bill of Materials**

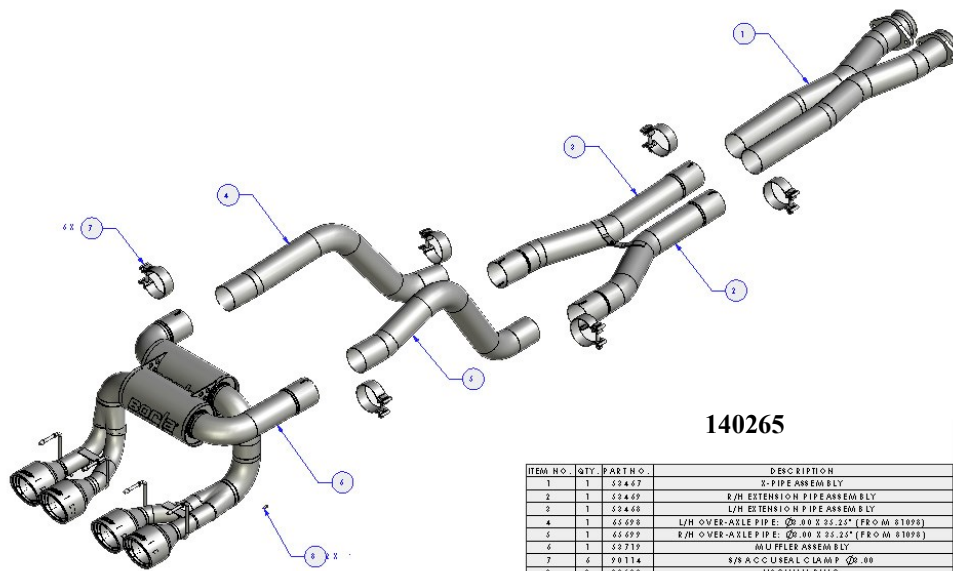

**140265**

ITEM NO.	QTY.	PART NO.	DESCRIPTION
1	1	52467	X-PIPE ASSEMBLY
2	1	52469	R/H EXTENSION PIPE ASSEMBLY
3	1	52468	L/H EXTENSION PIPE ASSEMBLY
4	1	65698	L/H OVER-AXLE PIPE: Ø3.00 X 35.25" (FROM 61898)
5	1	65699	R/H OVER-AXLE PIPE: Ø3.00 X 35.25" (FROM 61898)
6	1	52719	MUFFLER ASSEMBLY
7	6	90114	S/S ACCUSEAL CLAMP Ø3.00
8	2	98539	VACUUM PLUG

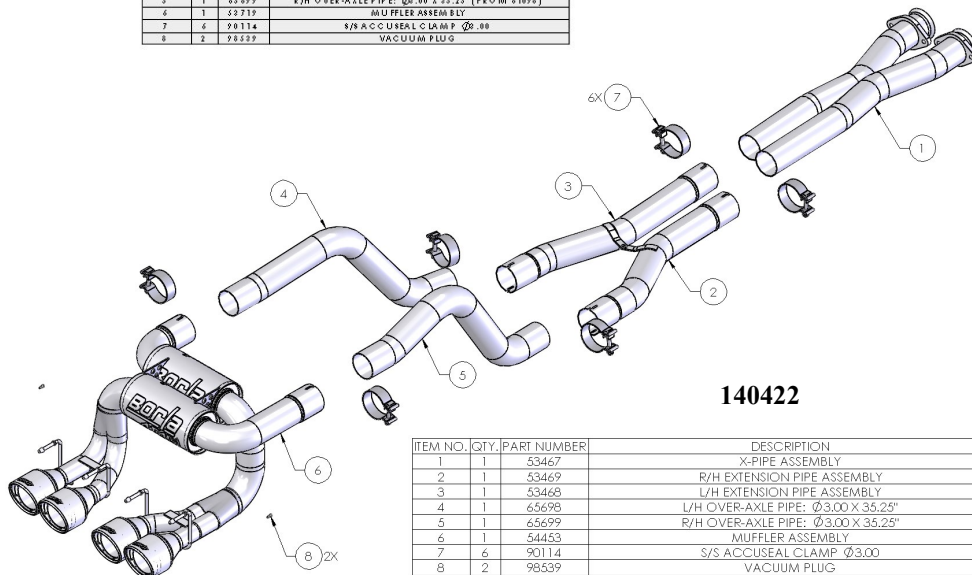

**140422**

ITEM NO.	QTY.	PART NUMBER	DESCRIPTION
1	1	53467	X-PIPE ASSEMBLY
2	1	53469	R/H EXTENSION PIPE ASSEMBLY
3	1	53468	L/H EXTENSION PIPE ASSEMBLY
4	1	65698	L/H OVER-AXLE PIPE: Ø3.00 X 35.25"
5	1	65699	R/H OVER-AXLE PIPE: Ø3.00 X 35.25"
6	1	54453	MUFFLER ASSEMBLY
7	6	90114	S/S ACCUSEAL CLAMP Ø3.00
8	2	98539	VACUUM PLUG

**Bill of Materials**

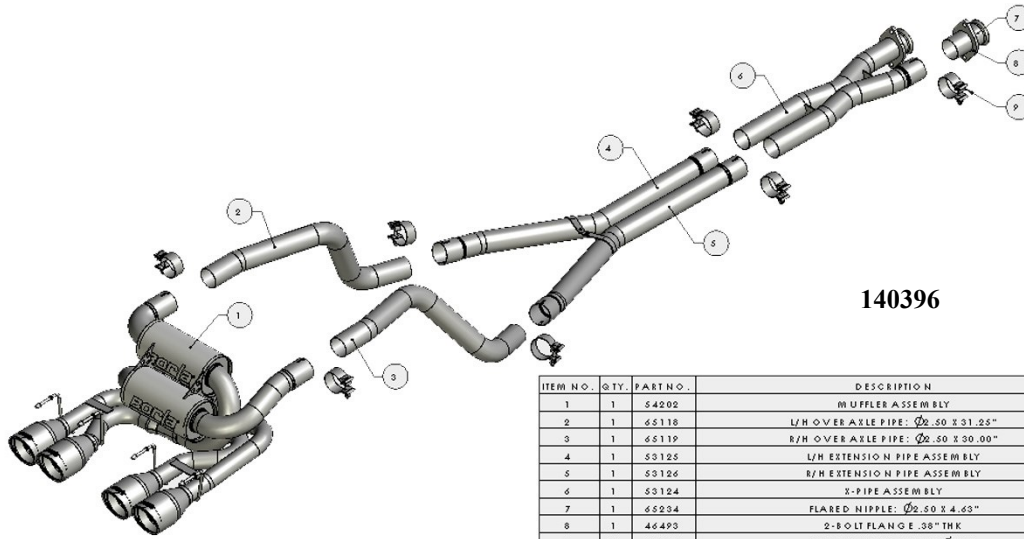

**140396**

ITEM NO.	QTY.	PART NO.	DESCRIPTION
1	1	54202	MUFFLER ASSEMBLY
2	1	65118	L/H OVER AXLE PIPE: Ø2.50 X 31.25"
3	1	65119	R/H OVER AXLE PIPE: Ø2.50 X 30.00"
4	1	53125	L/H EXTENSION PIPE ASSEMBLY
5	1	53126	R/H EXTENSION PIPE ASSEMBLY
6	1	53124	X-PIPE ASSEMBLY
7	1	65234	FLARED NIPPLE: Ø2.50 X 4.63"
8	1	46493	2-BOLT FLANGE .38" THK
9	7	90113	S/S ACCUSEAL CLAMP Ø2.50

**SYSTEM 140131**

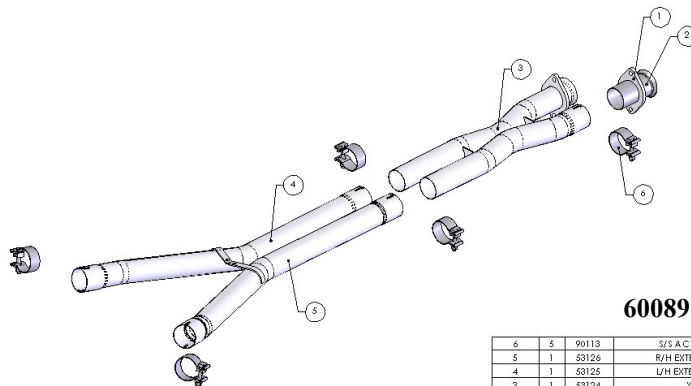

**60089**

6	5	90113	S/S ACCUSEAL CLAMP Ø2.50
5	1	53126	R/H EXTENSION PIPE ASSEMBLY
4	1	53125	L/H EXTENSION PIPE ASSEMBLY
3	1	53124	X-PIPE ASSEMBLY
2	1	65234	FLARED NIPPLE: Ø2.50 X 4.63"
1	1	46493	2-BOLT FLANGE .38" THK
ITEM NO.	QTY.	PART NO.	DESCRIPTION

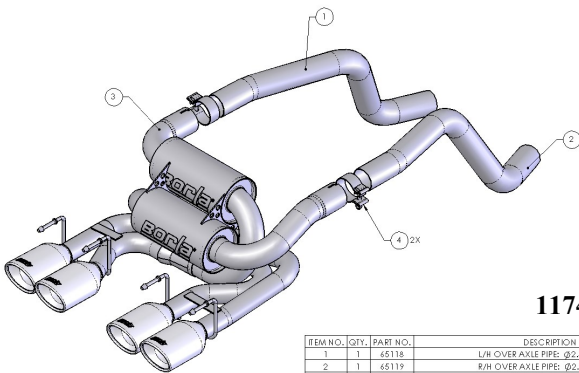

**11746**

ITEM NO.	QTY.	PART NO.	DESCRIPTION
1	1	65118	L/H OVER AXLE PIPE: Ø2.50 X 31.25"
2	1	65119	R/H OVER AXLE PIPE: Ø2.50 X 30.00"
3	1	53102	MUFFLER ASSEMBLY
4	2	90113	S/S ACCUSEAL CLAMP Ø2.50

**Caution!!! Never work on a hot exhaust system. Serious injury in the form of burns can result** If the vehicle has been in use and the exhaust system is hot, allow vehicle to cool for at least 1 hour. Always wear eye protection when working under any vehicle.

*Note: It is our recommendation that you use a hoist or hydraulic lift to facilitate the installation of your new Borla Performance X-Pipe.*

Taking all under car safety precautions, lift the vehicle using a hoist or hydraulic lift. Once this has been done, you may begin the removal of your old exhaust system from your vehicle.

## System Removal

*Note: With a used vehicle, we suggest a penetrating spray lubricant to be applied liberally to all exhaust fasteners and allowing a significant period of time for the chemical to lubricate the threads before attempting to disassemble.*

1. Loosen the clamps located under the transmission at the rear of the vehicle. (See Fig.1)
2. Using a 13mm socket, unbolt the spring hangers located in front of the clamps. Place the bolts aside for use during the installation of your new exhaust system. (See Fig.2)
3. With a muffler stand or an additional person to hold the h-pipe assembly up into position. Unbolt the flanges (15mm socket) located just behind the catalytic converters. Place the hardware and gaskets aside for use during the installation of your new Borla Performance X-Pipe. (See Fig.3)
4. Remove the h-pipe assembly from the vehicle by dropping the front downwards. Slide the rear pipes from the factory over axle pipe/muffler assemblies. (See Fig.4)

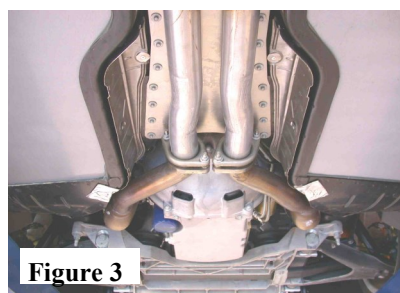
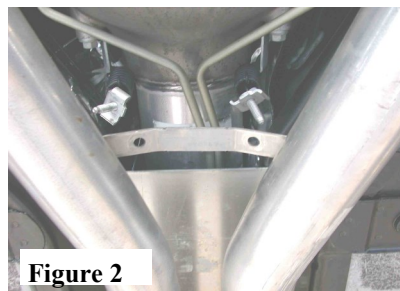

## System Removal (continued)

5. Unbolt the rear anti sway bar and swing it down and out of the way. (See Fig. 5)
6. Remove the vacuum hose from each valve located on each muffler at the rear of the vehicle just above the tips. (See Fig.6)
7. Lubricate all hangers and rubber isolators.
8. Before removing the muffler assemblies, because of the tight clearances on this vehicle, it may be required to unplug and move some of the electrical connectors located at the rear of the vehicle above the over axle pipes. (See Fig. 7)
9. Beginning with the passenger side muffler assembly; using a muffler stand or an additional person to hold the muffler assembly up into place, remove the hangers from the rubber isolators and carefully remove the muffler assembly from the vehicle. (See Fig. 8)
11. Repeat step 9 for the removal of the driver side muffler assembly.



Figure 5



Figure 6



Figure 7



Figure 8



Figure 9

**Warning:** Use extreme caution during installation. Torque all fasteners according to manufacturer's torque values and tightening sequence. **DO NOT** use air impact tools to tighten fasteners on Borla Performance Exhaust Systems. Use of such tools may result in bent flanges or gasket contact areas leading to exhaust leaks.

## Borla Performance Cat-Back Installation

1. Using the original hardware and gaskets, install the X pipe assembly into position. (See Fig. 9) Hand tighten the hardware for now.
2. Place a clamp over the expanded end of both left and right extension pipes and place them into position. (See Fig. 10) Do Not tighten clamps.
3. Using the original hardware, attach the spring hangers to the extension pipes. (See Fig. 11)
4. Place a clamp over the expanded ends of both left and right extension pipes and install the over axle pipes. (See Fig. 12) Do Not tighten clamps.
5. Place a clamp over the expanded ends of both left and right over axle pipe making sure the hardware is facing downward. (See Fig. 13) Do Not tighten clamps.
6. Carefully place the muffler assembly into position making sure to install the hangers into the rubber isolators. (See Fig. 14) Do Not tighten clamps.
7. Check your exhaust system for proper clearance under the vehicle and also for tip alignment.
8. Once position has been determined to be correct, tighten the Accuseal clamps to 32-35 ft. lbs. and the front flanges to 35-40 ft. lbs.
9. Using the original hardware, reinstall the sway bar. Torque the upper bolts to 45-49 ft. lbs. And the lower nuts to 65-70 ft. lbs.
10. If any connectors or wires had to be moved to allow for clearance during the removal or installation of your exhaust, reconnect them and install them into their original positions.
11. Insert the vacuum plugs included with your system into the vacuum hoses at the rear of vehicle.
12. Before starting your vehicle, make sure to check all wires, hoses, brake lines, body parts and tires for safe clearance from the exhaust system.
13. Start vehicle and check for any leaks. If any leaks are found, determine cause (such as loose or incorrectly positioned clamp) and repair as necessary.

*Note: When you first start your vehicle after the installation of your new Borla Performance X-Pipe, there may be some smoke and fumes coming from exhaust. This is a protective oil based coating used in the manufacturing of mandrel bent performance exhaust tubing. This is not a problem and will disappear within a very short period of time after the exhaust has reached normal operating temperatures.*



**Figure 10**



**Figure 11**



**Figure 12**



**Figure 13**



**Figure 14**