

Exhaust System Installation For Corvette C6 PN's-11753, 11822



These instructions have been written to help you with the installation of your Borla Performance Exhaust System. Please read this document completely before beginning the installation of your system.

Please compare the parts in the box with the bill of materials provided to assure that you have all the parts necessary for this installation.

To ensure this part number fits your specific model year, please visit our website for the latest model year listings at www.BORLA.com.

Thank you for purchasing a Borla Performance Rear-Section Exhaust System.

This Borla Performance Rear Section Exhaust System (11753, 11822) is designed for Chevrolet Corvette Z06 equipped with a 7.0L V-8 engine and a manual transmission.

Borla Performance Industries recommends that an exhaust shop or professional after market parts installer, who has all the necessary equipment, tools and experienced personnel needed for proper installation, should perform the installation of this system. However, if you decide to perform the installation, we recommend someone should help you. Ensure the installer uses all under car safety precautions including eye protection.

Please take time to read and understand the following...

By installing your Borla Performance Exhaust System, you indicate that you have read this document and you agree with the terms stated below.

It is the responsibility of the purchaser to follow all installation instruction guidelines and safety procedures supplied with your Borla Performance Exhaust System

Borla Performance Industries assumes no responsibility for damages occurring from misuse, abuse, improper installation, improper operation, lack of responsible care, or all previously stated reasons resulting from incompatibility with other manufacturer's products and/or systems.

Included with your Borla Performance Exhaust System is a warranty card. Please read it carefully before you begin any work on your vehicle. If you should have any questions regarding our warranty policy, installation, or any other matter pertaining to your new Borla Performance Exhaust System, please give us a call at the number provided on the warranty card.

Minimum Required Tool List:

TOOLS:

1. 3/8" Drive Ratchet
2. 3/8" Drive Extension 3"
3. 15mm Deep Well Socket
4. Pry Bar

SHOP SUPPLIES:

- 1 Spray Lubricant

Borla Performance Cat-back™ Bill of Materials

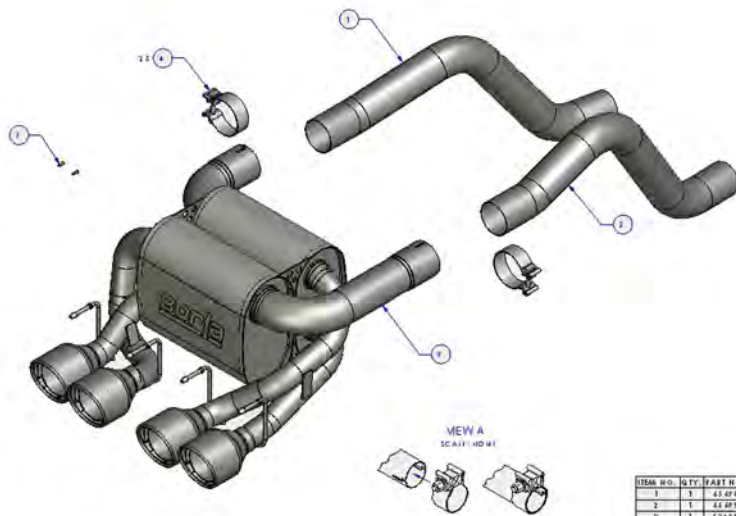

11753

ITEM NO.	QTY.	PART NO.	DESCRIPTION
1	1	65494	1/2" OVER-ALLE PIPE, 03.00 X 36.25" (1100481078)
2	1	65499	3/4" OVER-ALLE PIPE, 03.00 X 36.25" (1100481079)
3	1	98114	5/8" OVER-ALLE PIPE
4	2	98114	5/8" ACCUSURE CLAMP, 03.00
5	2	98539	VACUUM PLUG

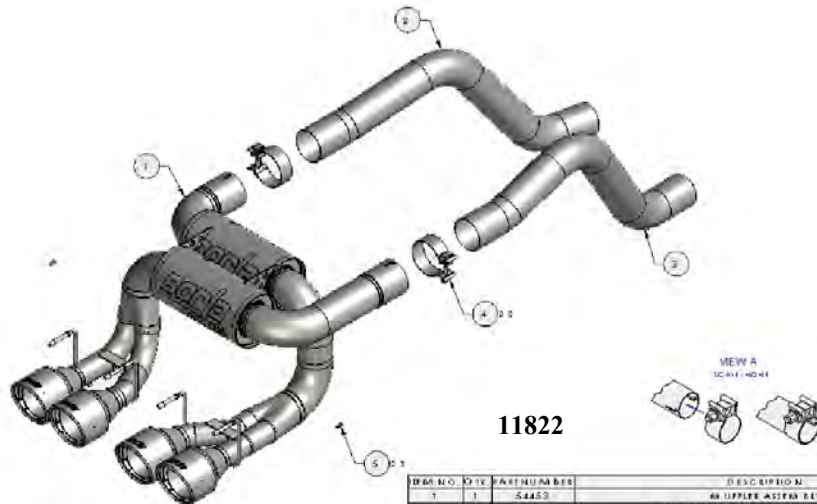

11822

ITEM NO.	QTY.	PART NUMBER	DESCRIPTION
1	1	65493	5/8" OVER-ALLE PIPE
2	1	65499	1/2" OVER-ALLE PIPE, 03.00 X 36.25"
3	1	65499	3/4" OVER-ALLE PIPE, 03.00 X 36.25"
4	0	98114	5/8" OVER-ALLE PIPE, 03.00 X 36.25"
5	2	98539	VACUUM PLUG

Caution!!! *Never work on a hot exhaust system. Serious injury in the form of burns can result* If the vehicle has been in use and the exhaust system is hot, allow vehicle to cool for at least 1 hour. Always wear eye protection when working under any vehicle.

Note: It is our recommendation that you use a hoist or hydraulic lift to facilitate the installation of your new Borla Performance Rear Section Exhaust System.

Taking all under car safety precautions, lift the vehicle using a hoist or hydraulic lift. Once this has been done, you may begin the removal of your old exhaust system from your vehicle.

Note: Before removing the original exhaust system from your vehicle, please compare the parts you have received with the bill of materials provided on the previous page to assure that you have all the parts necessary for the installation of your new Borla Performance Rear Section Exhaust System.

Original Exhaust System Removal

Note: With a used vehicle, we suggest a penetrating spray lubricant to be applied liberally to all exhaust fasteners and allowing a significant period of time for the chemical to lubricate the threads before attempting to disassemble.

1. Remove two top bolts and two bottom nuts securing the anti-sway bar leaving the bottom bolts, which run through the lower control arm in place.
2. Swing the anti-sway bar down and out of the way as shown in figure 1.
3. Loosen the clamps shown in figure 2 located just under the transmission at the rear of the vehicle.
4. Using a 13mm socket, unbolt the spring hangers located just in front of the clamps as shown in figure 3. Place the bolts aside for use during the installation of your new exhaust system.
5. With a muffler stand or an additional person to hold the h-pipe assembly up into position, using a 15mm socket, unbolt the flanges shown in figure 4 located just behind the catalytic converters. Place the hardware and gaskets to the side for use during the installation of your new exhaust system.
6. Remove the h-pipe assembly from the vehicle by dropping the front down, then sliding the rear portion out of the factory over axle pipe/muffler assemblies.
7. Remove the vacuum lines as the one shown in figure 5 from each muffler assembly and insert the plugs included with your new system into each line. Tuck the vacuum lines away into the bumper.
8. Using a spray type lubricant, lubricate the hangers at the rear of the vehicle just above the tip assemblies.
9. Beginning with the passenger's side of the vehicle, remove the hangers from the rubber isolators and remove the muffler assembly from the vehicle as shown in figure 6.
10. Repeat step 9 for the removal of the driver's side muffler assembly.



Figure 1



Figure 2



Figure 3



Figure 4



Figure 5

Warning: Use extreme caution during installation. Torque all fasteners according to manufacturer's torque values and tightening sequence. DO NOT use air impact tools to tighten fasteners on Borla Performance Exhaust Systems. Use of such tools may result in bent flanges or gasket contact areas leading to exhaust leaks.

Borla Performance Rear Section Exhaust System Installation

1. Re-install the H pipe assembly as shown in figure 7 in the opposite order of removal and using the original hardware, reinstall the spring hangers. Hand tighten the flange hardware for now.
2. Place the original clamps over the expanded ends of the H pipe and install the left and right over axle pipes as shown in figure 8. Do Not tighten the clamps.
3. Place a clamp over each over axle pipe as shown in figure 9.
4. Set the muffler into position as shown in figure 10, inserting the over axle pipes into the muffler inlet pipes. Using a muffler stand or an additional person to hold it into position, install the hangers into the rubber isolators. Do Not tighten the clamps.
5. Check your exhaust system for proper clearance under the vehicle and also for tip alignment.
6. Once position has been determined to be correct, tighten the Accuseal clamps to 32-35 ft. lbs. making sure the clamp opening is not over any of the notches in the pipe and the front flanges to 35-40 ft. lbs.
7. Swing the anti-sway bar back into position as shown in figure 11 re-installing the original hardware previously removed. Torque the upper bolts to 45-49 ft. lbs. And the lower nuts to 65-70 ft. lbs.
8. Before starting your vehicle, make sure to check all wires, hoses, brake lines, body parts and tires for safe clearance from the exhaust system.
9. Start vehicle and check for any leaks. If any leaks are found, determine cause (such as loose or incorrectly positioned clamp) and repair as necessary.

Congratulations!!! You have completed the installation of the world famous Borla Performance Stainless Steel Exhaust System.

Note: When you first start your vehicle after the installation of your new Borla Performance Exhaust System, there may be some smoke and fumes coming from the system. This is a protective oil based coating used in the manufacturing of mandrel bent performance exhaust tubing. This is not a problem and will disappear within a very short period of time after the exhaust has reached normal operating temperatures.



Figure 6



Figure 7



Figure 8



Figure 9



Figure 10



Figure 11