

PERRIN

Steering Dampener Lockdown for 2008+ WRX

2018-10-11

Thank you for purchasing this PERRIN product for your car! Installation of this product should only be performed by persons experienced with installation of aftermarket performance parts and proper operation of high performance vehicles. If vehicle needs to be raised off the ground for installation, the installer must use proper jacks, jack-stands and/or a professional vehicle hoist for safety of the installer and to protect property. If the vehicle is lifted improperly, serious injury or death may occur! Please read through all instructions before performing any portion of installation. If you have any questions, please contact our tech department prior to starting installation. We can be reached in any of the following methods:

Email Tech@PERRINperformance.com

Instant Chat off the main page of www.PERRINperformance.com

Or simply call our tech team at 503-693-1702

GENERAL MODIFICATION NOTE

Modifications to any vehicle can change the handling and performance. As with any vehicle, extreme care must be used to prevent loss of control or roll-over during sharp turns or abrupt maneuvers. Always wear seat belts, and drive safely, recognizing that reduced speeds and specialized driving techniques may be required. Failure to drive a vehicle safely may result in serious injury or death. Do not drive a vehicle unless you are familiar with its unique handling characteristics and are confident of your ability to maintain control under all driving conditions. Some modifications (and combinations of modifications) are not recommended and may not be permitted in your state or country. Consult the owner's manual, service manual, instructions accompanying these products, and local laws before purchasing and installing these modifications. You are responsible for the legality and safety of the vehicle you modify using these components.

SPECIAL NOTES:

- Expect added feedback through the steering wheel after installation. It is normal to feel things like ruts in the road or small bumps in the steering wheel as you hit potholes.
- Using a spray lube or grease is highly recommended when installing the two halves into the steering dampener.

Included Parts with PERRIN Steering Dampener Lockdown Kit:

- (1) PERRIN Steering Dampener Lockdown Set (Left and Right)
- (1) M6x60 Socket Cap Screw SS
- (1) M6x70 Socket Cap Screw SS
- (1) M5 Hex Wrench
- (1) Thread Locker Compound



Installation Instructions

1. Open hood and locate steering rack universal joint as shown above. This is located below the brake master cylinder and next to heater core coolant hoses. **NOTE#1: It may be helpful to use zip ties to hold wires and hoses out of way during installation. NOTE#2: If your universal joint looks different than this (missing dampener portion) stop installation and call PERRIN tech support.**
2. Locate and loosen (2) 12mm bolts on top and bottom of steering rack universal joint as shown in picture below. **Note: Picture shows universal joint removed from car for reference only. Do NOT remove universal joint from car.**

Unscrew Bolts Roughly 2 Full Turns

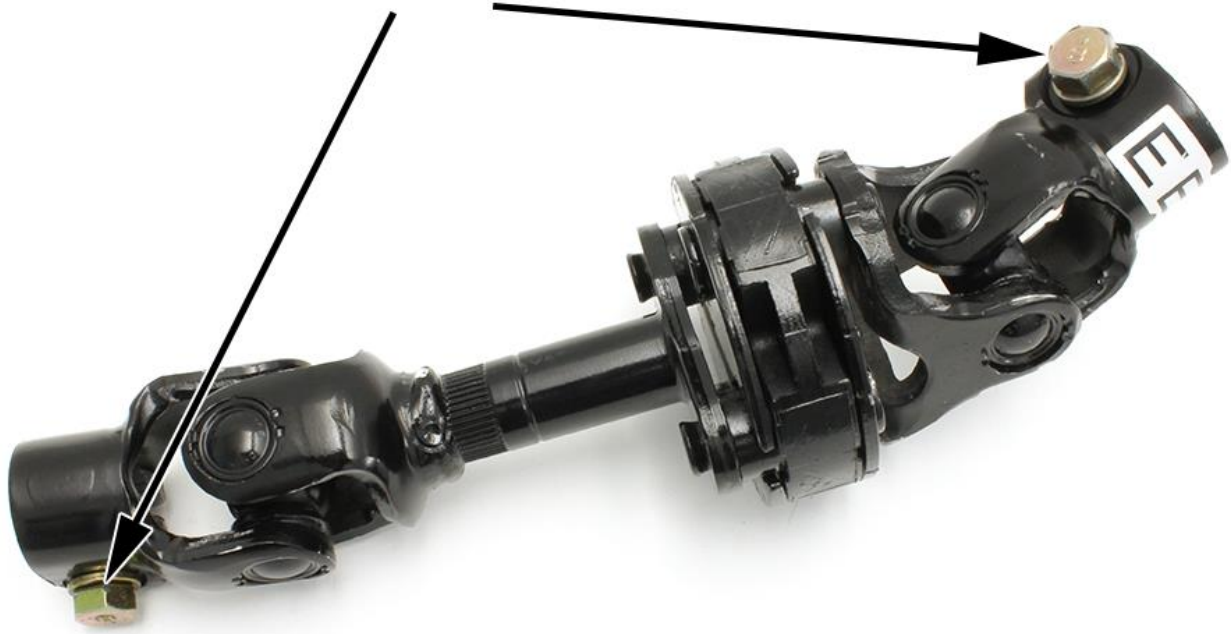

3. Rotate steering wheel until dampener lines up similar to pictures below.
4. Install both halves of PERRIN Steering Dampener Lockdown to each side of dampener (as shown below) and thread supplied M6x70 bolt through both halves. **NOTE: We recommend lubricating OEM dampener (where the lockdown parts touch) with a spray lube to make installation slightly easier.**

Using Longer M6 Bolt, Attach Each Half Together As Shown

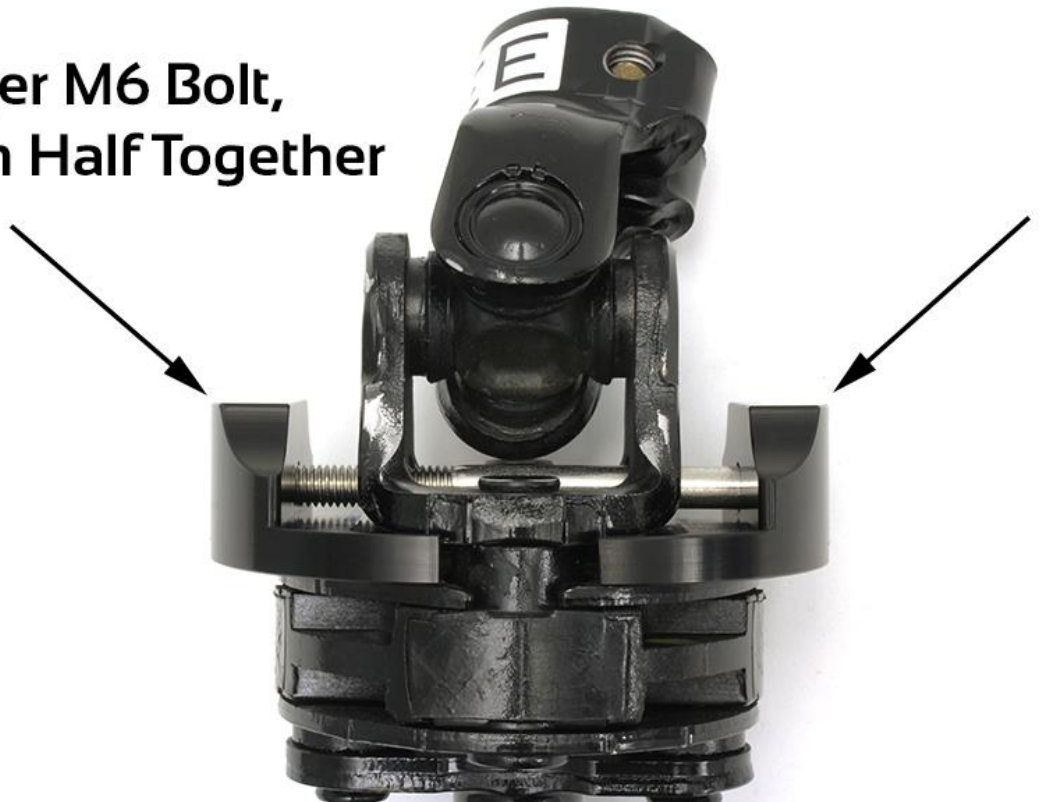

- Using supplied wrench, slowly tighten bolt compressing both halves together. Once the bolt is tight (both halves should be touching upper half of universal joint and bolt will be sticking out of one side) remove bolt from PERRIN Steering Dampener Lockdown.

**Fully Tighten Longer
M6 Bolt, Then Remove
And Install Shorter
M6 Bolt.**



- Using supplied thread locking compound, apply a few drops to threaded portion of M6x60 bolt.
- Install M6x60 bolt through both halves of PERRIN Steering Dampener Lockdown and tighten bolt to roughly 10ft-lbs.
- With steering wheel unlocked, rotate steering wheel $\frac{1}{2}$ of a turn to the left and $\frac{1}{2}$ of a turn to the right.
- Re-tighten (2) 12mm bolts on steering rack universal joint to 17.4ft-lbs.
- Periodically inspect M6 bolt to ensure it is tightened properly.

Questions, Comments, and Suggestions Contact: Tech@PERRINperformance.com

Visit Our Website for Instant Chat Options at www.PERRINperformance.com

Call Our Tech Team at 503-693-1702